

ITEM NO.	PART NUMBER	DESCRIPTION	10598-02/QTY.
1	19616-03	END PLUG	1
2	19615	RETAINER, QUAD	1
3	19669	END PLUG EXTENSION	1
4	40078	O-RING, 28MM X 2MM	1
5	BR10209	QUAD RING,-010	1

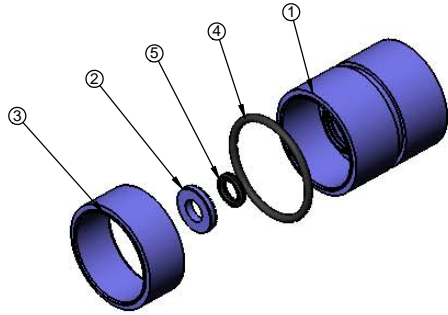

10598-02  
END PLUG ASSY,2750, NHWP,DF

ITEM NO.	PART NUMBER	DESCRIPTION	10598-01/QTY.
1	14453	BUSHING HW	1
2	10234-01	O-RING, -.024, 560CD	1
3	10212	PLUG, END, 1500/2750, BRASS	1
4	10209-01	QUAD RING,-010, 560CD	1

NOTE:  
STAKE ITEM 2 PER SIWI-50.15.

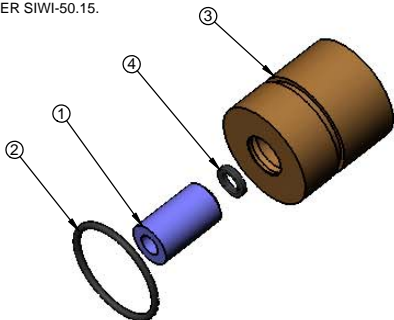

10598-01  
END PLUG ASSY,HOT WATER

REVISIONS					
ZONE	ECN	REV.	DESCRIPTION	DATE	APP'D
			CREATED DRAWING ON SOLIDWORKS		TRK
	15038	B	10598-031 MADE INTO SEPARATE DRAWING	12-8-05	AB
	15602	C	ADDED -031 CONFIGURATION	08-10-06	AB
	15369	D	ADDED STAKING REQUIREMENT NOTE TO -01VERSION, ERROR CORRECTION: FIXED POSITION OF P/N 14453	12-18-06	JJR
	100432	E	REPLACED NOTE FOR 10592-01 WITH CURRENT, ADDED 2750 TO DRAWING TITLE	04-16-2012	AB

ITEM NO.	PART NUMBER	DESCRIPTION	10598/ QTY.	10598-001/ QTY.	10598-031/ QTY.
1	10234-01	O-RING, -.024, 560CD	-	1	1
2	BR41131	END PLUG	1	1	-
3	41133	END PLUG, TOP, 2750, UPFLOW	-	-	1
4	40078	O-RING, 28MM X 2MM	1	-	-
5	BU13008	RETAINER, END PLUG SEAL	1	1	1
6	BR10209	QUAD RING,-010	1	-	-
7	10209-01	QUAD RING,-010, 560CD	-	1	1

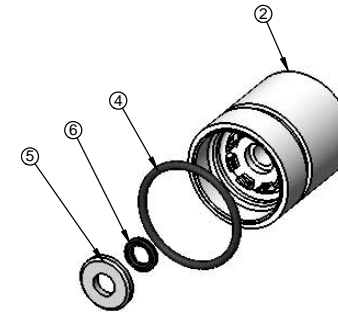

10598  
END PLUG ASSY

10598-001  
END PLUG ASSY,2750/2900, 560CD

10598-031  
END PLUG ASSY,2750,UF, 560CD



FOR 10598-031; SEE SEPARATE DRAWING

LAST SAVED IN SMARTTEAM: 08/10/2006 15:28		CRITICALITY SYMBOLS PER QPSP-001.2		PARTS LIST	
<input type="checkbox"/> LEVEL I <input checked="" type="checkbox"/> LEVEL II <input type="checkbox"/> LEVEL III		THIS DRAWING MUST BE COMPARED TO THE ERP SYSTEM TO ENSURE CORRECT REVISION LEVEL PRIOR TO USE.			
THIS DOCUMENT IS SOLELY THE PROPERTY OF PENTAIR WATER TREATMENT. REPRODUCTION, USE, DISCLOSURE, OR TRANSMISSION OF THIS DOCUMENT OR DETAILS CONTAINED HEREIN, IN PART OR IN WHOLE, IS PROHIBITED WITHOUT THE WRITTEN CONSENT OF PENTAIR WATER TREATMENT ENGINEERING. THIS DOCUMENT AND ANY COPIES SHALL BE RETURNED TO PENTAIR WATER TREATMENT UPON WRITTEN REQUEST.		THIRD ANGLE PROJECTION		Pentair Water Treatment	
DO NOT SCALE DRAWING. DIMS. ARE IN INCHES (mm) INTERPRET DIMS AND TOLERANCES PER ASME Y14.5M-1994 UNLESS OTHERWISE SPECIFIED CORNER FILLETS R.005-.020 (.127-.508) TOLERANCES: ANGLES ±1° 1 PLACE .X ±.015 2 PLACE .XX ±.01 3 PLACE .XXX ±.005		APPROVALS	DATE	P.O. BOX 730 BROOKFIELD, WI 53008-0730	
DRAWN rsm		DATE	TITLE END PLUG ASSY		
CHECKED		DATE	SIZE C	DWG NO. 10598	REV C
APPROVED		DATE	SCALE 1:1	SOLIDWORKS FORMAT	SHEET 1 OF 1