

ITEM	QTY	PART NO.	DESCRIPTION	NOM
1	5	10872	SCREW	VIS
2	1	15493	SPRING PIN	GOUPILLE
3	1	18725	INDICATOR, SERVICE / STB-BY	INDICATEUR SERVICE / STB-BY
4	1	18727	CURVED SPRING WASHER	RONDELLE ELASTIQUE
5	1	24188	ADAPTOR BRACKET MOTOR ASSY 2900 DUPLEX A	EQUERRE MOTEUR ASSEMBLE 2900 DX A
6	1	24214	ADAPTOR DRIVE CAM ASSY 2900	ADAPTEUR CAME D'eNTRAINEMENT ASSEMBLE 2900
7	1	40388	DRIVE MOTOR 24v 50 Hz	MOTEUR 24v 50 Hz

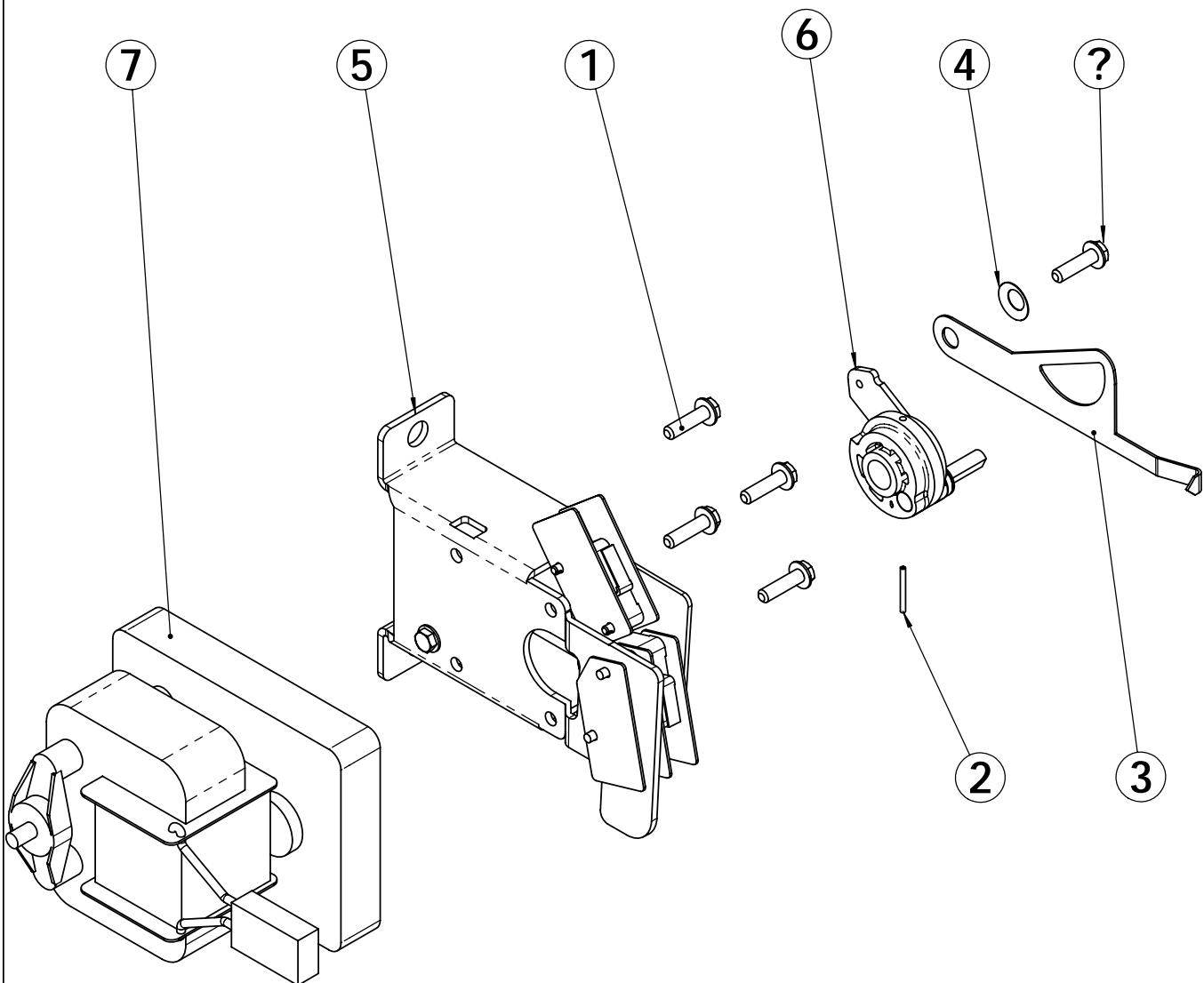

ITEM	QTY	PART NO.	DESCRIPTION	NOM
1	5	10872	SCREW	VIS
2	1	15493	SPRING PIN	GOUPILLE
3	1	18725	INDICATOR, SERVICE / STB-BY	INDICATEUR SERVICE / STB-BY
4	1	18727	CURVED SPRING WASHER	RONDELLE ELASTIQUE
5	1	24188	ADAPTOR BRACKET MOTOR ASSY 2900 DUPLEX A	EQUERRE MOTEUR ASSEMBLE 2900 DX A
6	1	24214	ADAPTOR DRIVE CAM ASSY 2900	ADAPTEUR CAME D'eNTRAINEMENT ASSEMBLE 2900
7	1	40387	DRIVE MOTOR 110v 50/60 Hz	MOTEUR 110v 50/60 Hz

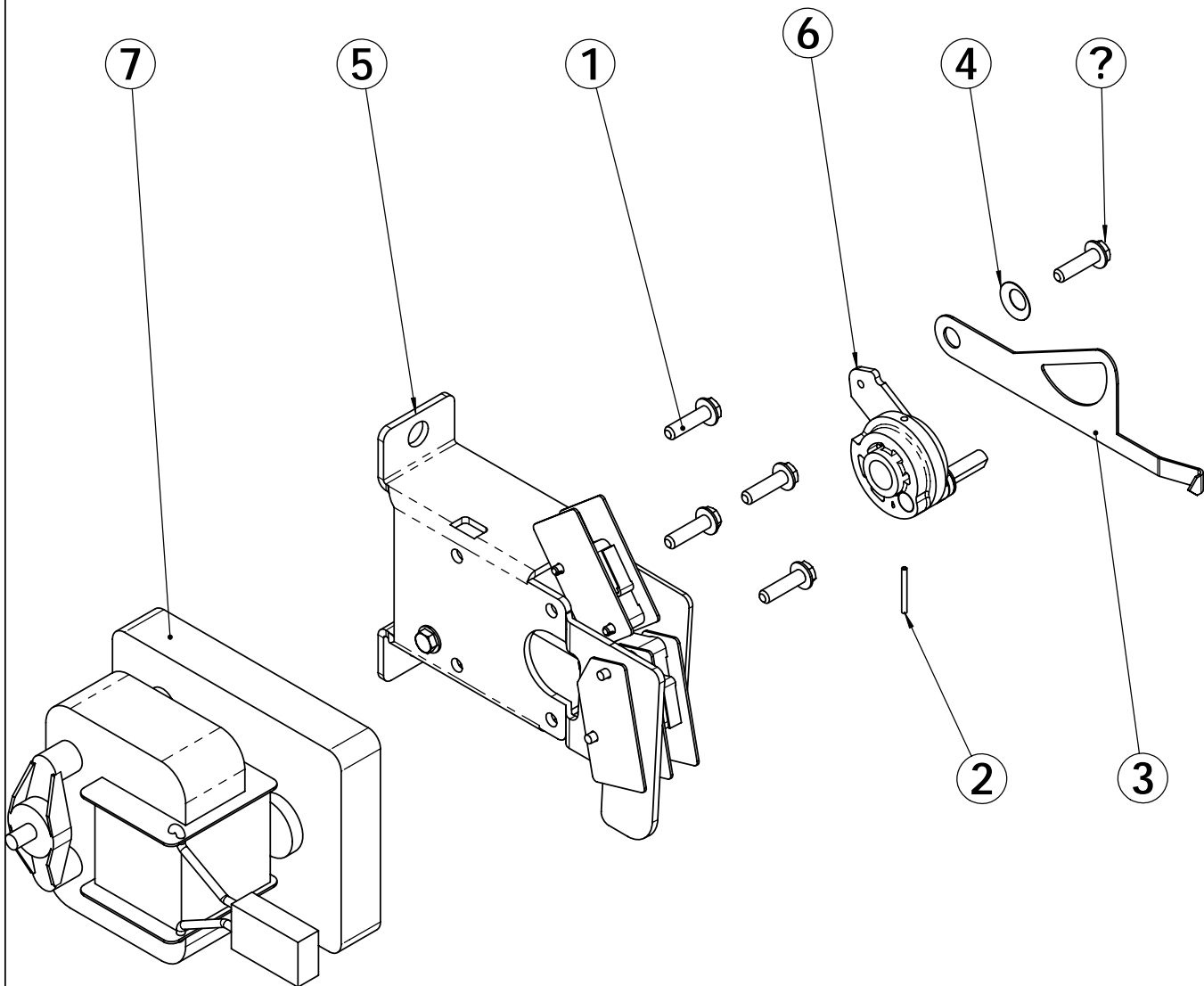

ITEM	QTY	PART NO.	DESCRIPTION	NOM
1	5	10872	SCREW	VIS
2	1	15493	SPRING PIN	GOUPILLE
3	1	18725	INDICATOR, SERVICE / STB-BY	INDICATEUR SERVICE / STB-BY
4	1	18727	CURVED SPRING WASHER	RONDELLE ELASTIQUE
5	1	24188	ADAPTOR BRACKET MOTOR ASSY 2900 DUPLEX A	EQUERRE MOTEUR ASSEMBLE 2900 DX A
6	1	24214	ADAPTOR DRIVE CAM ASSY 2900	ADAPTEUR CAME D'eNTRAINEMENT ASSEMBLE 2900
7	1	40389	DRIVE MOTOR 230v 50 Hz	MOTEUR 230v 50 Hz