

OBSOLETE
 SEE ECO F5254

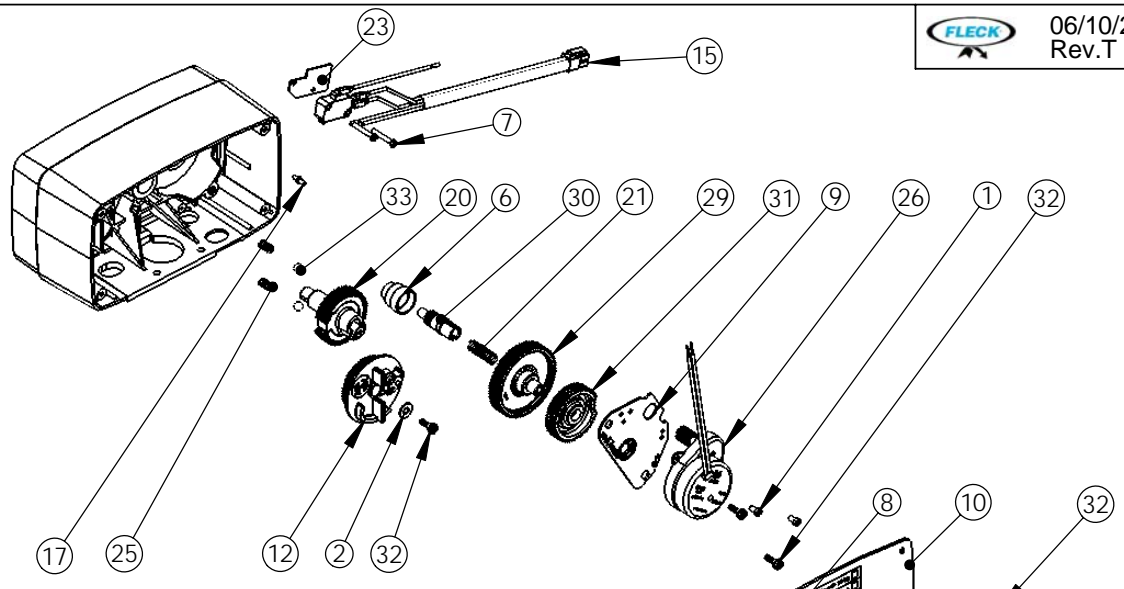

ITEM	QTY	PART NO.	DESCRIPTION	NOM
1	2	11384	SCREW	VIS
2	1	12037	WASHER	RONDELLE
3	1	13009-21	24 HOURS PRINTED GEAR	ROUE 24 HEURES
4	1	13162-02	DRIVE HOUSING, BLACK	BOTIER, NOIR
5	2	13311	IDLER SHAFT SPRING	RESSORT
6	1	14051	SLEEVE IDLER GEAR HOLE	SLEEVE IDLER GEAR HOLE
7	2	18158	SCREW	VIS
8	1	21271	SERIAL NUMBER LABEL	ETIQUETTE No DE SERIE
9	1	23341	PLATE MOTOR MOUNTING	PLAQUE DE MONTAGE MOTEUR
10	1	24099	BACK COVER ASSY 5600	COUVERCLE ARRIERE 5600
11	1	24100	SKIPPER WHEEL 12 DAYS ASSY	ROUE ASSEMBLEE 12 JOURS
12	1	24121-XX	BRINE CAM DF ASSY 5600-ND MECA	CAME DE SAUMURAGE ASSEMBLEE 5600/ND MECA
13	1	24750	LABEL CONTROL KNOB.5650 ECO DVGW	ETIQUETTE BOUTTON 5650 ECO DVGW
14	1	25651	24v. STANDARD TRANSFORMER	TRANSFORMATEUR STANDARD 24v
15	1	26667	WIRE HARNESS	FAISCEAU
16	1	28192	FRONT LABEL 5600 CHRONO NO LAMPS	LABEL 5600 CHRONO SANS LAMPES
17	1	28202	MOTOR PIN	PIN MOTEUR
18	1	28312	FRONT PANEL ASSY 5600 FORUM	ENSEMBLE FACE AVANT 5600 FORUM
19	1	BR13014	REGENERATION POINTER	
20	1	BR13170	GEAR & SHAFT, MAIN	ROUE D'ENTRAINEMENT
21	1	BR13312	IDLER SHAFT SPRING	RESSORT
22	1	BR13547-0	STRAIN RELIEF, ROUND CORD	PASSE CABLE
23	1	BR14087	INSULATOR	ISOLATEUR
24	1	BR14177	KNOB, CONTROL	BOUTON DE CONTROL
25	2	BR14457	SPRING, DETENT	RESSORT
26	1	BR18826-1	MOTOR, 120V-60HZ 1/30 RPM	
27	2	BR40422	WIRE NUT	CONNECTEUR
28	1	BU13011	CYCLE ACTUATOR ARM	DOIGT DE DECLENCHEMENT
29	1	BU13017	IDLER GEAR	PIGNON
30	1	BU13018	IDLER SHAFT	PIGNON
31	1	BU13164	GEAR, DRIVE	ROUE D'ENTRAINEMENT
32	8	BU13296	SCREW #6-20 * 0.50 long	Vis
33	4	BU13300	BALL 1/4"	BILLE 1/4"
34	1	BU13864	SKIPPER WHEEL RING	ANNEAU ROUE SAUTEUSE
35	1	BU15151	SCREW	VIS
36	1	BU26963	VALVE POSIT. DIAL PICTO 5600 STD/LWU	CADRAN DE POSITION PICTO 5600 STD/LWU
37	1	BU28552	TRANSFORMER WIRE HARNESS	FAISCEAU DU TRANSFORMATEUR

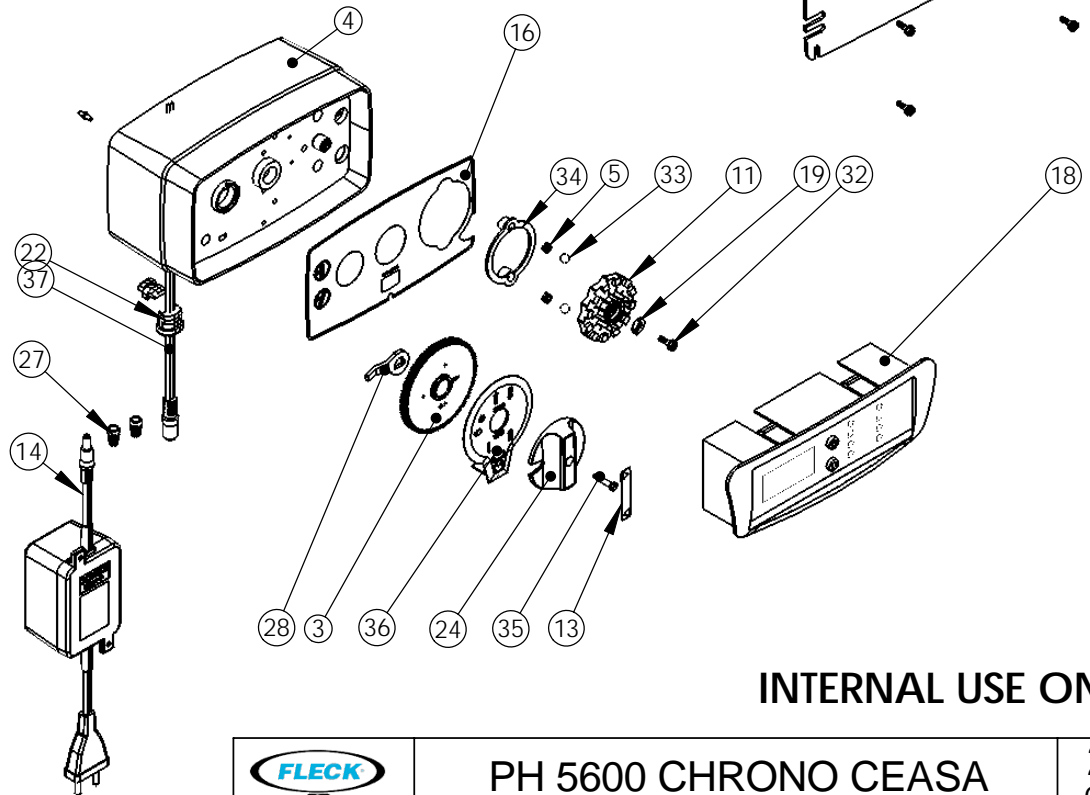

INTERNAL USE ONLY