

2

1

REVISIONS

ZONE	ECN	REV.	DESCRIPTION	DATE	APP'D
	12051	A	RELEASE FOR PRODUCTION	02-24-04	PWS
	12218	B	B1 ADD BAG P/N 16895, B2 ADD P/N 41162	04-01-04	PWS

ITEM NO.	QTY	PART NUMBER	DESCRIPTION
1	1	40951	O-RING, -220
2	1	40565	CONNECTOR, 1 1/4" NPT, 7000

B

B

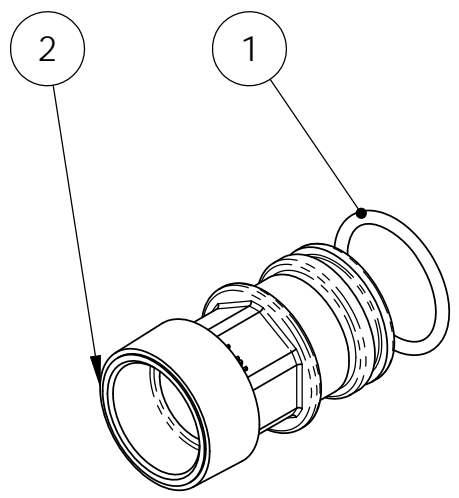

EDO for CAD SYSTEM
OBSOLETE FOR SAP SYSTEM

SEE ECO F5554

NOTES:

- ASSEMBLE PART 2 TO PART 1.
- PLACE ASSEMBLY IN BAG P/N 16895
- USE SERVICE ASSEMBLE ACCEPTANCE I.D. LABEL

THIS DOCUMENT IS SOLELY THE PROPERTY OF PENTAIR WATER TREATMENT. REPRODUCTION, USE DISCLOSURE, OR TRANSMISSION OF THIS DOCUMENT OR DETAILS CONTAINED HEREIN, IN PART OR IN WHOLE, IS PROHIBITED WITHOUT THE WRITTEN CONSENT OF PENTAIR WATER TREATMENT ENGINEERING. THIS DOCUMENT AND ANY COPIES SHALL BE RETURNED TO PENTAIR WATER TREATMENT UPON WRITTEN REQUEST.

DO NOT SCALE DRAWING. DIMS. ARE IN INCHES [mm]
INTERPRET DIMS AND TOLERANCES PER ASME Y14.5M -1994
UNLESS OTHERWISE SPECIFIED:
CORNER FILLETS R.005-.020 [.127-.508]
TOLERANCES:

- ANGLES : ± 1°
- 1 PLACE .X: ± .015
- 2 PLACE .XX: ± .01
- 3 PLACE .XXX: ± .005

A

A

PARTS LIST

THIS DRAWING MUST BE COMPARED TO THE ERP SYSTEM TO ENSURE CORRECT REVISION LEVEL PRIOR TO USE.

LAST SAVED IN SMARTTEAM:
04/09/2004 14:27



P.O. BOX 730
BROOKFIELD, WI 53008-0730

CRITICALITY SYMBOLS PER QPSP-001.2

<input type="checkbox"/>	LEVEL I
<input checked="" type="checkbox"/>	LEVEL II
<input checked="" type="checkbox"/>	LEVEL III

APPROVALS	DATE
DRAWN pws	02/25/2004
CHECKED NAME	DATE
APPROVED NAME	DATE

TITLE CONNECTOR ASM, 1 1/4" NPT w/O-RING		
SIZE A	DWG NO. 40565-01	REV B
SCALE 1:1	SOLIDWORKS FORMAT	SHEET 1 OF 1

2

↑

1