

2

1

REVISIONS

ZONE	ECN	REV.	DESCRIPTION	DATE	APP'D
	12051	A	RELEASE FOR PRODUCTION	02-24-04	PWS
	12218	B	B1 ADD BAG P/N 16895, B2 ADD P/N 41162	04-01-04	PWS

ITEM NO.	QTY	PART NUMBER	DESCRIPTION
1	1	BR40951	O-RING, -220
2	1	40565-10	CONNECTOR, 1 1/4" BSP, 7000

B

B

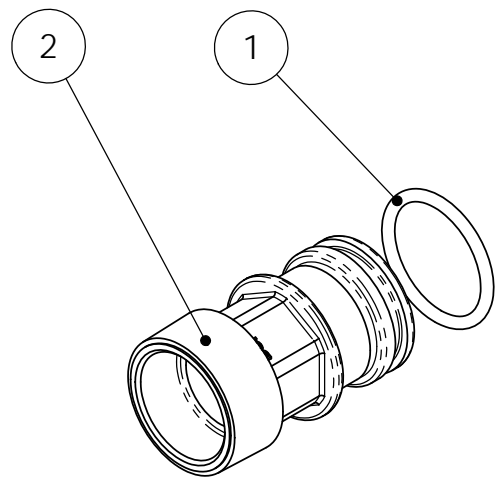

NOTES:

(B2)
(B1)

- ASSEMBLE PART 2 TO PART 1.
PART 2 TO BE LUBRICATED P/N 41162
- PLACE ASSEMBLY IN BAG P/N 16895
- USE SERVICE ASSEMBLE ACCEPTANCE I.D. LABEL

THIS DOCUMENT IS SOLELY THE PROPERTY OF PENTAIR WATER TREATMENT. REPRODUCTION, USE DISCLOSURE, OR TRANSMISSION OF THIS DOCUMENT OR DETAILS CONTAINED HEREIN, IN PART OR IN WHOLE, IS PROHIBITED WITHOUT THE WRITTEN CONSENT OF PENTAIR WATER TREATMENT ENGINEERING. THIS DOCUMENT AND ANY COPIES SHALL BE RETURNED TO PENTAIR WATER TREATMENT UPON WRITTEN REQUEST.

- DO NOT SCALE DRAWING
- DIMENSIONS = INCH/[mm]
- TOLERANCES (UNLESS OTHERWISE SPECIFIED)

	INCH	[mm]
1	± 0.015	± 0.40
0.1	± 0.015	± 0.25
0.01	± 0.010	± 0.13
0.001	± 0.005	

ANGULAR ± 1°
BREAK ALL EXPOSED SHARP CORNERS .010 [.25] X 45° MAX.

PARTS LIST

THIS DRAWING MUST BE COMPARED TO THE ERP SYSTEM TO ENSURE CORRECT REVISION LEVEL PRIOR TO USE.

A

A

LAST SAVED IN SMARTTEAM: 04/09/2004 14:28	THIRD ANGLE PROJECTION	
CRITICALITY SYMBOLS PER QPSP-001.2 <input type="checkbox"/> LEVEL I <input checked="" type="checkbox"/> LEVEL II <input type="checkbox"/> LEVEL III	APPROVALS	DATE
	DRAWN	DATE
	CHECKED	DATE
	APPROVED	DATE
	NAME	DATE
	NAME	DATE

P.O. BOX 730 BROOKFIELD, WI 53008-0730		
TITLE CONNECTOR ASSY, 1 1/4" BSP w/O-ring		
SIZE A	DWG NO. 40565-11	REV B
SCALE 1:1	SOLIDWORKS FORMAT	SHEET 1 OF 1

2

↑

1