

ASSEMBLY #	DESCRIPTION		
61454-000	INJECTOR ASSY, #000, 7000		
ITEM #	PART NUMBER	DESCRIPTION	QTY
1	18274-000	NOZZLE, INJECTOR, #000, BROWN	1
2	18275-000	THROAT, INJECTOR, #000, BROWN	1
3	40969-01	CAGE, BALL, MACH, 7000, INJECTOR	1
4	13771-01	O-RING, -012	2
5	BR10209-01	QUAD RING, -010	1
6	40962	BALL, 1/4", POLYPROPYLENE	1
7	41111	DISPERSER	1

ASSEMBLY #	DESCRIPTION		
61454-00	INJECTOR ASSY, #00, 7000		
ITEM #	PART NUMBER	DESCRIPTION	QTY
1	18274-00	NOZZLE, INJECTOR, #00, VIOLET	1
2	18275-00	THROAT, INJECTOR, #00, VIOLET	1
3	40969-01	CAGE, BALL, MACH, 7000, INJECTOR	1
4	13771-01	O-RING, -012	2
5	BR10209-01	QUAD RING, -010	1
6	40962	BALL, 1/4", POLYPROPYLENE	1
7	41111	DISPERSER	1

ASSEMBLY #	DESCRIPTION		
61454-0	INJECTOR ASSY, #0, 7000		
ITEM #	PART NUMBER	DESCRIPTION	QTY
1	18274-0	NOZZLE, INJECTOR, #0, RED	1
2	18275-0	THROAT, INJECTOR, #0, RED	1
3	40969-01	CAGE, BALL, MACH, 7000, INJECTOR	1
4	13771-01	O-RING, -012	2
5	BR10209-01	QUAD RING, -010	1
6	40962	BALL, 1/4", POLYPROPYLENE	1
7	41111	DISPERSER	1

ASSEMBLY #	DESCRIPTION		
61454-1	INJECTOR ASSY, #1, 7000		
ITEM #	PART NUMBER	DESCRIPTION	QTY
1	18274-1	NOZZLE, INJECTOR, #1, WHITE	1
2	18275-1	THROAT, INJECTOR, #1, WHITE	1
3	40969-01	CAGE, BALL, MACH, 7000, INJECTOR	1
4	13771-01	O-RING, -012	2
5	BR10209-01	QUAD RING, -010	1
6	40962	BALL, 1/4", POLYPROPYLENE	1
7	41111	DISPERSER	1

ASSEMBLY #	DESCRIPTION		
61454-2	INJECTOR ASSY, #2, 7000		
ITEM #	PART NUMBER	DESCRIPTION	QTY
1	18274-2	NOZZLE, INJECTOR, #2, BLUE	1
2	18275-2	THROAT, INJECTOR, #2, BLUE	1
3	40969-01	CAGE, BALL, MACH, 7000, INJECTOR	1
4	13771-01	O-RING, -012	2
5	BR10209-01	QUAD RING, -010	1
6	40962	BALL, 1/4", POLYPROPYLENE	1

ASSEMBLY #	DESCRIPTION		
61454-3	INJECTOR ASSY, #3, 7000		
ITEM #	PART NUMBER	DESCRIPTION	QTY
1	18274-3	NOZZLE, INJECTOR, #3, YELLOW	1
2	18275-3	THROAT, INJECTOR, #3, YELLOW	1
3	40969-01	CAGE, BALL, MACH, 7000, INJECTOR	1
4	13771-01	O-RING, -012	2
5	BR10209-01	QUAD RING, -010	1
6	40962	BALL, 1/4", POLYPROPYLENE	1

ASSEMBLY #	DESCRIPTION		
61454-4	INJECTOR ASSY, #4, 7000		
ITEM #	PART NUMBER	DESCRIPTION	QTY
1	18274-4	NOZZLE, INJECTOR, #4, GREEN	1
2	18275-4	THROAT, INJECTOR, #4, GREEN	1
3	40969-01	CAGE, BALL, MACH, 7000, INJECTOR	1
4	13771-01	O-RING, -012	2
5	BR10209-01	QUAD RING, -010	1
6	40962	BALL, 1/4", POLYPROPYLENE	1

ASSEMBLY #	DESCRIPTION		
61454-5	INJECTOR ASSY, #5, 7000		
ITEM #	PART NUMBER	DESCRIPTION	QTY
1	18274-5	NOZZLE, INJECTOR, #5, GRAY	1
2	18275-5	THROAT, INJECTOR, #5, GRAY	1
3	40969-01	CAGE, BALL, MACH, 7000, INJECTOR	1
4	13771-01	O-RING, -012	2
5	BR10209-01	QUAD RING, -010	1
6	40962	BALL, 1/4", POLYPROPYLENE	1

REVISIONS					
ZONE	ECN	REV.	DESCRIPTION	DATE	APP'D
	10646	B	RELEASE DRAWING	03-31-03	PWS
	11246	C	RELEASE PART NUMBERS INTO PRODUCTION, ADDED NOTES 8 & 9.	8-28-03	PWS
	11467	D	D1 WAS KIT, D2 WAS KIT, D3 ADD BAG P/N, D4 REVISED NOTE, D5 ADD NOTE	10-16-03	PWS
	16359	E	UPDATED EXPLODED VIEW; CORRECTED ASSEMBLY MATES; ADDED SECTION VIEW; NO ENGINEERING/SPECIFICATION CHANGES	09-08-06	STM
	16663	F	UPDATED BOM FOR ALL CONFIGURATIONS: 10209-01 WAS 10209	01-12-07	STM

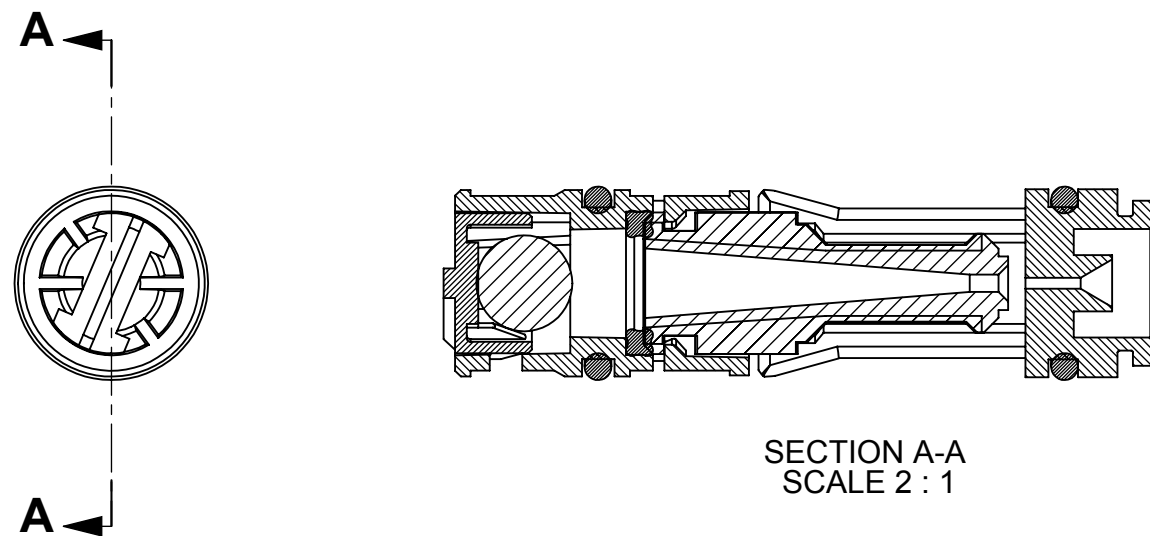
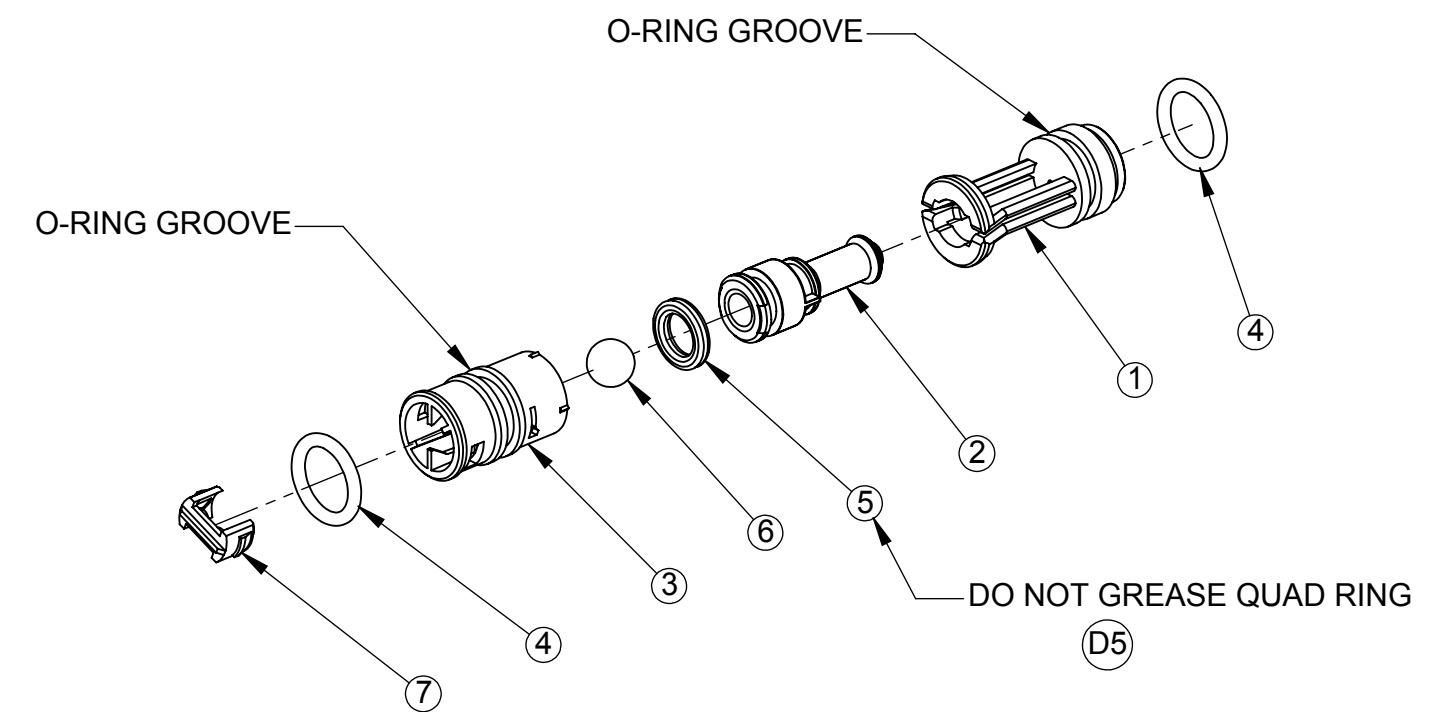

ASSEMBLY INSTRUCTIONS

- 1) BALL (ITEM #6) PLACED INTO CAGE (ITEM #3).
- 2) QUAD RING (ITEM #5) PLACED IN GROOVE INSIDE CAGE (ITEM #3).
- 3) THROAT (ITEM #2) PLACED IN CAGE (ITEM #3) ALIGNING TABS OF CAGE WITH SLOTS IN THROAT FLANGE, WHEN THROAT IS IN PLACE, ROTATE 1/4 TURN (90°).
- 4) NOZZLE (ITEM #1) SNAPPED IN PLACE ON THROAT (ITEM #3).
- 5) O-RING (ITEM #4) PLACED IN GROOVE IN MIDDLE OF CAGE (ITEM #3).
- 6) O-RING (ITEM #4) PLACED IN GROOVE OF NOZZLE (ITEM #1).
- 7) ON ASSEMBLIES -000, -00, -0, -1, DISPERSER (ITEM #7) IS SNAPPED INTO SLOTS OF CAGE (ITEM #3).
- NOTE: DO NOT PUT DISPERSER (ITEM#7) IN CAGE (ITEM #3) OF ASSEMBLIES -2, -3, -4, -5.
- (D3) 8) PLACE ASSEMBLY IN BAG P/N 16895
- (D4) 9) USE SERVICE ASSEMBLY ID LABEL.

LAST MODIFIED: 01/30/2007 11:28

CRITICALITY SYMBOLS PER QPSP-001.2

□ LEVEL I □ LEVEL II ■ LEVEL III

THIS DOCUMENT IS SOLELY THE PROPERTY OF PENTAIR WATER TREATMENT. REPRODUCTION, USE DISCLOSURE, OR TRANSMISSION OF THIS DOCUMENT OR DETAILS CONTAINED HEREIN, IN PART OR IN WHOLE, IS PROHIBITED WITHOUT THE WRITTEN CONSENT OF PENTAIR WATER TREATMENT ENGINEERING. THIS DOCUMENT AND ANY COPIES SHALL BE RETURNED TO PENTAIR WATER TREATMENT UPON WRITTEN REQUEST.

DO NOT SCALE DRAWING. DIMS. ARE IN INCHES [mm]
INTERPRET DIMS AND TOLERANCES PER ASME Y14.5M -1994
UNLESS OTHERWISE SPECIFIED:
CORNER FILLETS R.005-.020 [127-508]
TOLERANCES:
ANGLES
1 PLACE X ± .5°
2 PLACE XX ± .015
3 PLACE XXX ± .005

PARTS LIST					
THIRD ANGLE PROJECTION		Pentair Water Treatment			
APPROVALS	DATE	P.O. BOX 730 BROOKFIELD, WI 53008-0730			
DRAWN	TJM	03/28/2003	TITLE INJECTOR ASSY, 7000		
CHECKED	NAME	DATE	SIZE	DWG NO.	REV
APPROVED	NAME	DATE	C	61454	F
			SCALE	SOLIDWORKS FORMAT	SHEET 1 OF 1
			1:1		