

REVISIONS					
ZONE	ECN	REV.	DESCRIPTION	DATE	APP'D
	11864	A	CREATED ON SOLIDWORKS	1-13-04	AB
	16687	B	REVISED PER MARKED UP DRAWINGS	1-24-07	AB

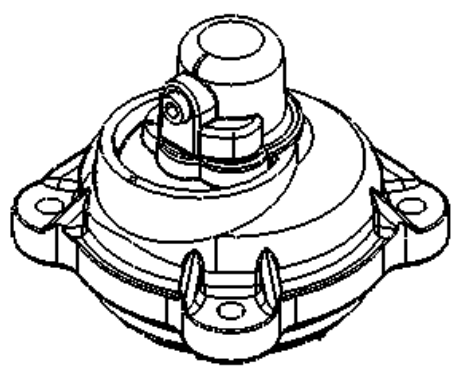

ISOMETRIC VIEW

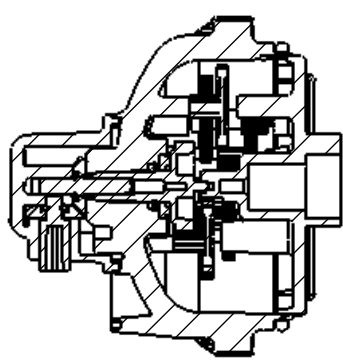

SECTION A-A

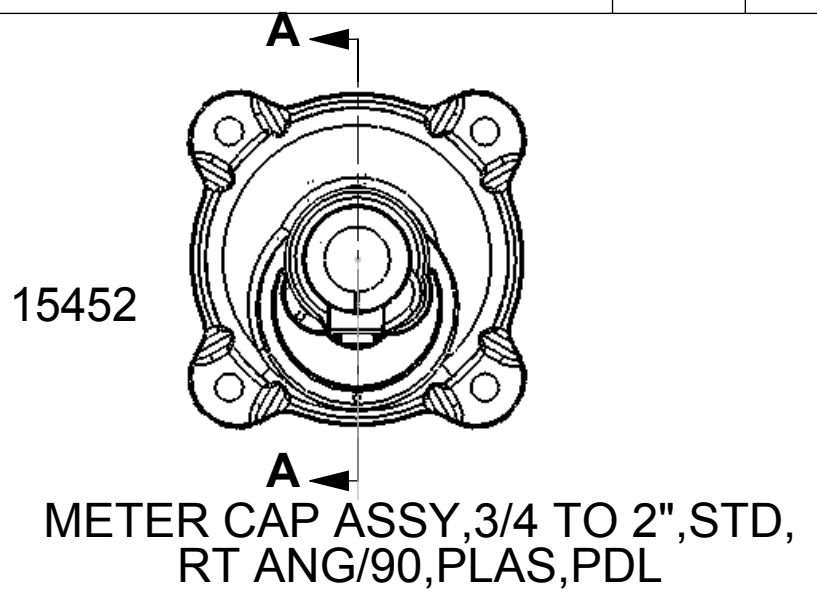

METER CAP ASSY, 3/4 TO 2", STD, RT ANG/90, PLAS, PDL

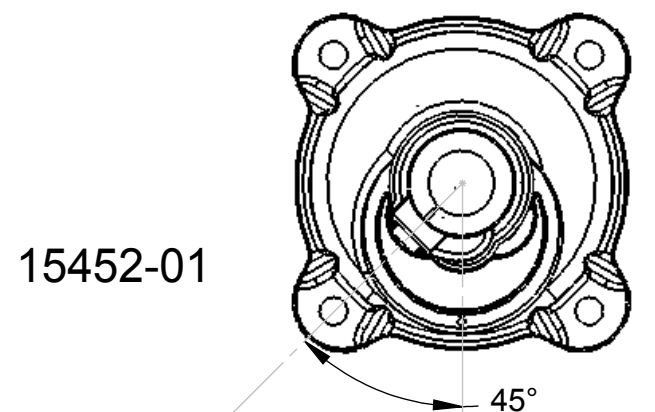

METER CAP ASSY, 3/4 TO 2", STD, RT ANG/45, PLAS, PDL

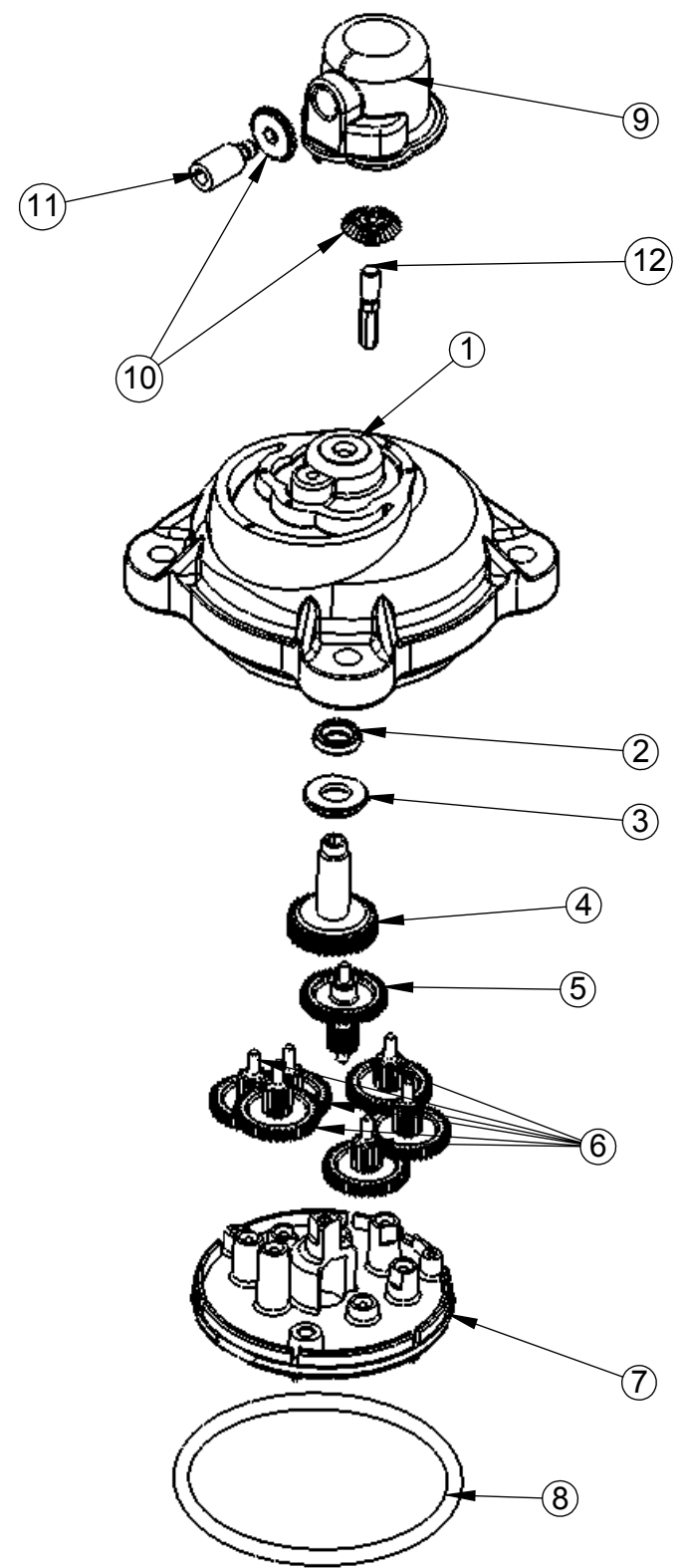

ITEM NO.	QTY.	PART NO.	DESCRIPTION
1	1	BR40986	CAP, METER
2	1	BR17711	SEAL, LIP
3	1	BR13832	RETAINER, SEAL
4	1	BR40180	GEAR OUTPUT METER
5	1	BR13825	GEAR, METER CHANGE LEVEL
6	6	BR13510	GEAR, IDLER
7	1	BR41055	PLATE, INTERMEDIATE
8	1	BR13847	O-RING, -137
9	1	BR40984	DOME, METER, R/ANGLE
10	2	BR15096	BEVEL GEAR, RIGHT ANGLE
11	1	BR15097	CABLE DRIVE SHAFT
12	1	BR15107	DRIVE, GEAR SHAFT(MAIN)

NOTES:
 ASSEMBLE PER DRAWING 42315WI
 SONIC WELD ASSEMBLY PER DRAWING 42313WI
 SONIC WELD PER DRAWING 42312WI

LAST SAVED IN SMARTTEAM: 05/05/2007 08:58

CRITICALITY SYMBOLS PER QPSP-001.2
 LEVEL I LEVEL II LEVEL III

THIS DOCUMENT IS SOLELY THE PROPERTY OF PENTAIR WATER TREATMENT. REPRODUCTION, USE DISCLOSURE, OR TRANSMISSION OF THIS DOCUMENT OR DETAILS CONTAINED HEREIN, IN PART OR IN WHOLE, IS PROHIBITED WITHOUT THE WRITTEN CONSENT OF PENTAIR WATER TREATMENT ENGINEERING. THIS DOCUMENT AND ANY COPIES SHALL BE RETURNED TO PENTAIR WATER TREATMENT UPON WRITTEN REQUEST.

DO NOT SCALE DRAWING. DIMS. ARE IN INCHES [mm]
 INTERPRET DIMS AND TOLERANCES PER ASME Y14.5M -1994
 UNLESS OTHERWISE SPECIFIED:
 CORNER FILLETS R.005-.020 [-.127-.508]
 TOLERANCES:
 ANGLES: ± 1°
 1 PLACE .X: ± .015 [0.38]
 2 PLACE .XX: ± .01 [0.3]
 3 PLACE .XXX: ± .005 [0.13]

THE COMPONENT, PART, OR ASSEMBLY DESCRIBED IN THIS DOCUMENT MUST COMPLY WITH THE FOLLOWING EU (EUROPEAN UNION) DEIRRECTIVES: RoHS DIRECTIVE 2002/95/EC, WEE DIRECTIVE 2002/96/EC, AND ELV DIRECTIVE 2000/53/EC. THESE DIRECTIVES RESTRICT THE USE OF LEAD, CADMIUM, MERCURY, CHROMIUM, PBB, PBDE, AND OTHER HAZARDOUS MATERIALS. SEE THE TERMS AND CONDITIONS OF THE CONTRACT (PURCHASE ORDER) FOR MORE INFORMATION.

THIS DRAWING MUST BE COMPARED TO THE ERP SYSTEM TO ENSURE CORRECT REVISION LEVEL PRIOR TO USE.

THIRD ANGLE PROJECTION				Pentair Water Brookfield P.O. BOX 730 BROOKFIELD, WI 53008-0730	
APPROVALS	DATE	TITLE			
		METER CAP ASSY, 3/4" TO 2", STD RT ANG, PLAS, PDL			
DRAWN	12/29/2003	SIZE	DWG NO.	REV	
CHECKED		B	BR15452	B	
APPROVED		SCALE	SOLIDWORKS FORMAT	SHEET 1 OF 1	
		1:1.5			