

2

1

REVISIONS					
ZONE	ECN	REV.	DESCRIPTION	DATE	APP'D
	12937	A	RELEASE FOR PRODUCTION	10-18-04	PWS

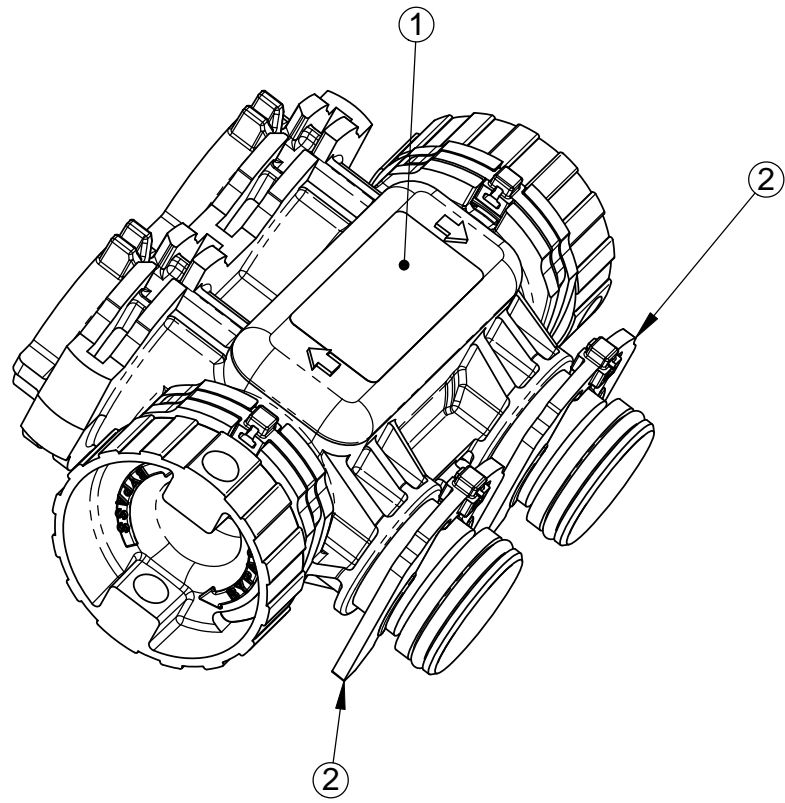

THIS DOCUMENT IS SOLELY THE PROPERTY OF PENTAIR WATER TREATMENT. REPRODUCTION, USE DISCLOSURE, OR TRANSMISSION OF THIS DOCUMENT OR DETAILS CONTAINED HEREIN, IN PART OR IN WHOLE, IS PROHIBITED WITHOUT THE WRITTEN CONSENT OF PENTAIR WATER TREATMENT ENGINEERING. THIS DOCUMENT AND ANY COPIES SHALL BE RETURNED TO PENTAIR WATER TREATMENT UPON WRITTEN REQUEST.

- NOTES:**
1. ATTACH 2 CLIPS, ITEM 2 TO MALE PORTS OF BYPASS ITEM 1.
  2. REPACKAGE IN ORIGINAL PACKAGING.

DO NOT SCALE DRAWING. DIMS. ARE IN INCHES [mm]  
 INTERPRET DIMS AND TOLERANCES PER ASME Y14.5M -1994  
 UNLESS OTHERWISE SPECIFIED:  
 CORNER FILLETS R.005-.020 [.127-.508]  
 TOLERANCES:  
 ANGLES : ± 1°  
 1 PLACE .X: ± .015  
 2 PLACE .XX: ± .01  
 3 PLACE .XXX: ± .005

ITEM NO.	QTY.	PART NO.	DESCRIPTION
1	1	BR40569	ASSEMBLY, BYPASS, HF35
2	2	BR40576	CLIP, H, PLASTIC, 7000

**PARTS LIST**

THIS DRAWING MUST BE COMPARED TO THE ERP SYSTEM TO ENSURE CORRECT REVISION LEVEL PRIOR TO USE.

LAST SAVED IN SMARTTEAM:  
 10/25/2004 12:35



**Pentair**  
 Water Treatment

P.O. BOX 730  
 BROOKFIELD, WI 53008-0730

**CRITICALITY SYMBOLS PER QPSP-001.2**

<input type="checkbox"/>	LEVEL I
<input checked="" type="checkbox"/>	LEVEL II
<input checked="" type="checkbox"/>	LEVEL III

APPROVALS	DATE
DRAWN pws	10/25/20
CHECKED NAME	DATE
APPROVED NAME	DATE

TITLE <b>BYPASS ASSEMBLY, 7000 W/CLIPS</b>			
SIZE <b>A</b>	DWG NO. <b>BR40569-01</b>	REV <b>A</b>	
SCALE 1:1	SOLIDWORKS FORMAT	SHEET 1 OF 1	

2

1