

ITEM NO.	PART NUMBER	DESCRIPTION	60232-010 /QTY.	60232-110 /QTY.	60232-110 /QTY.	60232-112 /QTY.	60232-130 /QTY.	60232-220 /QTY.	60232-310 /QTY.	60232-313 /QTY.	60232-610 /QTY.
1	BR14779-02	COVER,BOTTOM,BLACK	1	1	-	-	-	-	1	-	1
	BR14779-021	COVER,BOTTOM,BLACK,MACHD	-	-	-	-	-	-	-	1	-
	BR14779-06	COVER,BOTTOM,STORM GRAY	-	-	-	-	1	-	-	-	-
	BR14779-08	COVER,BOTTOM,COVENTRY BLUE	-	-	-	-	-	1	-	-	-
2	BR14779-04	COVER, TOP, BLACK	-	1	-	-	1	-	-	-	-
	BR14779-05	COVER, TOP, BIEGE	-	-	-	-	-	-	-	-	1
	BR14779-07	COVER, TOP, STORM GRAY	-	-	-	-	-	-	1	1	-
	BR14779-09	COVER, TOP, COVENTRY BLUE	-	-	-	-	-	1	-	-	-
3	BR14779-11	COVER, TOP, Balsa, WHITE	1	-	-	-	-	-	-	-	-
	BR13296	SCREW, HEX WSH, 6-20 X 1/2	-	-	-	2	-	-	-	-	-
4	BR19403	WINDOW, COVER,	-	-	-	1	-	-	-	-	
5	BR14932	NUT, SPEED, 8-32	-	2	-	-	-	-	-	2	
6	BR19291-020	COVER DESIGNER,	-	-	1	-	-	-	-	-	
7	BR19291-022	COVER DESIGNER, 1 PIECE, LEFT	-	-	-	1	-	-	-	-	

REVISIONS					
ZONE	ECN	REV.	DESCRIPTION	DATE	APP'D
	15231	A	RELEASED FOR PRE-PRODUCTION	12-27-05	JJR
	16387	B	1-WAS: 19203, 2-ADD'D: ROHS NOTE, 3- WAS: NOTES FOR 60232-110,	9-14-06	TJM
	17101	C	1-ADD'D TORQUE NOTE, 2-REMD TORQUE TABLE, 3-REMD NOTES FOR 60232-112, 4-ADD'D NOTE.	3-22-07	TJM
	17939	D	1-ADD'D: FABRICATION NOTES, 2- ADD'D: ALL WITHOUT WINDOW, 3- WAS: 60232-110, -112, 4- ADD'D: MAT'L CHART	3-31-08	AB
	19394	E	1-REMD: BR60232-000 BOM FROM CHART	8-21-09	AB

PART NO.	MATERIAL SPEC.
BR14779-02	MS8063 OR MS8995
BR14779-021	-
BR14779-04	MS8063 OR MS8995
BR14779-05	MS8007
BR14779-06	MS8004
BR14779-07	MS8004
BR14779-08	MS8006
BR14779-09	MS8005
BR14779-10	MS8006
BR14779-11	MS8006

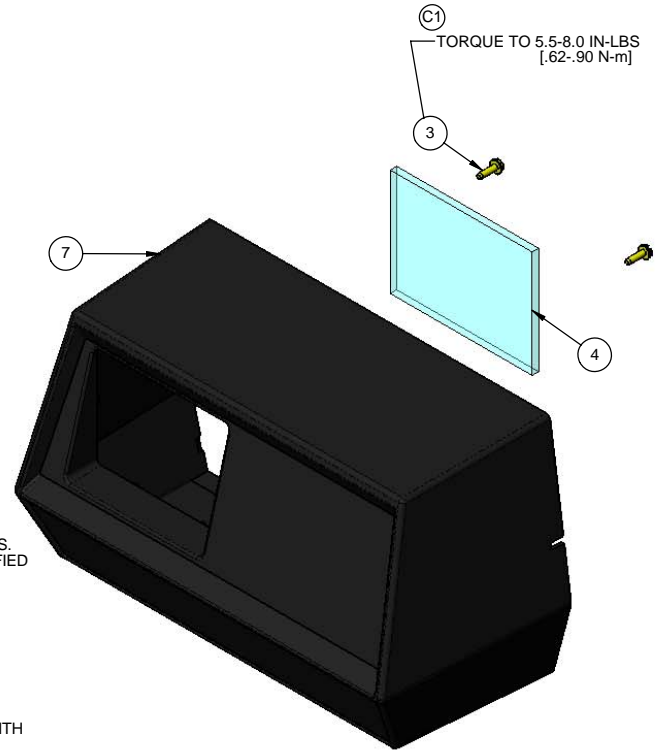
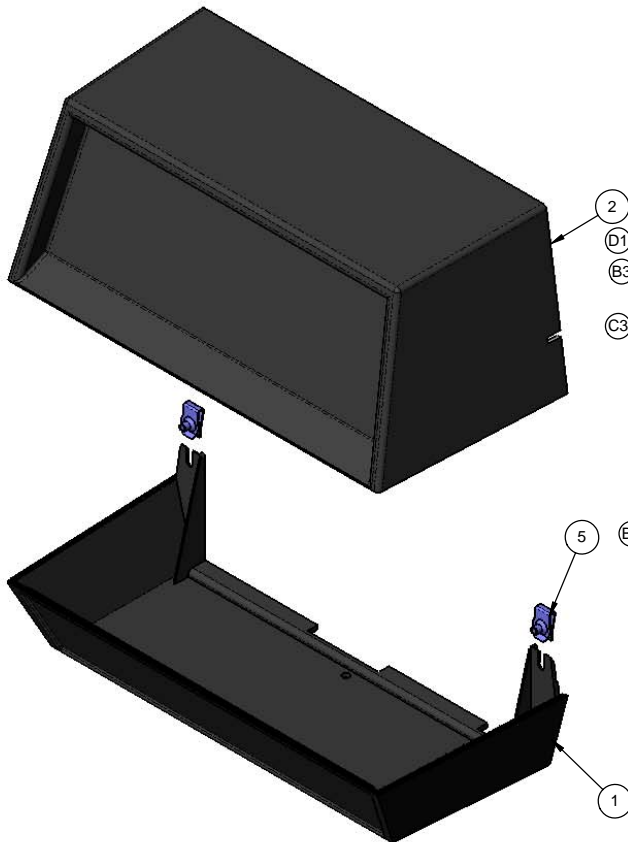

- FABRICATION INSTRUCTIONS:**
- MATERIAL: SEE CHART
  - DIMENSIONAL REQUIREMENTS PER DRAWING BR14779.
  - ULTRASONICALLY WELD TOP COVER TO BOTTOM COVER PER REQUIREMENTS ON DRAWING BR14779.
- ASSEMBLY INSTRUCTIONS:**
- REMOVE PROTECTIVE PAPER FROM BOTH SIDES OF WINDOW (ITEM 5).
  - PLACE WINDOW (ITEM 5) IN OPENING OF COVER (ITEM 4) AND POSITION IT BETWEEN POSTS.
  - PLACE SCREWS (ITEM 6) IN MOUNTING POSTS ON COVER (ITEM 4) AND TIGHTEN AS SPECIFIED TO SECURE WINDOW (ITEM 5).
  - INSURE THAT WINDOW (ITEM 5) COMPLETELY COVERS ALL EDGES OF WINDOW OPENING.
- PACKAGING/SHIPPING INSTRUCTIONS:**
- WIPE COVER WITH SOAP AND WATER MIXTURE BEFORE PACKAGING.
  - PLACE COVER IN POLY BAG. 1 PART PER POLY BAG.
  - PLACE COVER IN CARTON, 24 PARTS PER 21.5 x 21.5 x 12" DOUBLE WALL CARTON. PACK IN 3 NESTED ROWS OF 8 PARTS EACH.
- ROHS COMPLIANCE:**
- THE COMPONENT, PART, OR ASSEMBLY DESCRIBED IN THIS DOCUMENT MUST COMPLY WITH THE FOLLOWING EU (EUROPEAN UNION) DIRECTIVES: RoHS DIRECTIVE 2002/95/EC, WEE DIRECTIVE 2002/96/EC, AND ELV DIRECTIVE 2000/53/EC. THESE DIRECTIVES RESTRICT THE USE OF LEAD, CADMIUM, MERCURY, CHROMIUM, PBB, PBDE, AND OTHER HAZARDOUS MATERIALS. SEE THE TERMS AND CONDITIONS OF THE CONTRACT (PURCHASE ORDER) FOR MORE INFORMATION.

NOTE: FOR INTERNAL FLECK USE ONLY!  
WHEN MOUNTING THIS COVER ON A VALVE, TORQUE THE COVER SCREW TO 3.5-5.0 IN-LBS [.40-.56 N-m]

60232-010; -11; -130; -220; -310; -313; -610  
ALL WITHOUT WINDOW

LAST SAVED IN SMARTTEAM 08/26/2009 09:55	
CRITICALITY SYMBOLS PER QPSP-001.2	
<input type="checkbox"/> LEVEL I	<input checked="" type="checkbox"/> LEVEL II
THIS DOCUMENT IS SOLELY THE PROPERTY OF PENTAIR WATER TREATMENT. REPRODUCTION, USE DISCLOSURE, OR TRANSMISSION OF THIS DOCUMENT OR DETAILS CONTAINED HEREIN, IN PART OR IN WHOLE, IS PROHIBITED WITHOUT THE WRITTEN CONSENT OF PENTAIR WATER TREATMENT ENGINEERING. THIS DOCUMENT AND ANY COPIES SHALL BE RETURNED TO PENTAIR WATER TREATMENT UPON WRITTEN REQUEST.	
DO NOT SCALE DRAWING. DIMS. ARE IN INCHES (mm) UNLESS OTHERWISE SPECIFIED. CORNER FILLETS R.005-020 (127-.508) TOLERANCES: ANGLES: ±.1° 1 PLACE .X: ±.015 (0.38) 2 PLACE .XX: ±.01 (0.25) 3 PLACE .XXX: ±.005 (0.13)	THE COMPONENT, PART, OR ASSEMBLY DESCRIBED IN THIS DOCUMENT MUST COMPLY WITH THE EU (EUROPEAN UNION) DIRECTIVES: ROHS DIRECTIVE 2002/95/EC

THIS DRAWING MUST BE COMPARED TO THE ERP SYSTEM TO ENSURE CORRECT REVISION LEVEL PRIOR TO USE.	
THIRD ANGLE PROJECTION	
APPROVALS	DATE
RHO	12-27-05
CHECKED	
APPROVED	
Pentair Residential Filtration	
TITLE COVER, DESIGNER, ASSEMBLY WITH WINDOW	
SIZE C	DWG NO. BR60232
SCALE 1:2	SOLIDWORKS FORMAT SHEET 1 OF 1