

2

1

| REVISIONS |        |      |                            |          |       |
|-----------|--------|------|----------------------------|----------|-------|
| ZONE      | ECN    | REV. | DESCRIPTION                | DATE     | APP'D |
|           | 33603  | A    | RELEASE FOR PRE-PRODUCTION | 07SEP11  | PWS   |
|           | 100578 | B    | RELEASE FOR PRODUCTION     | 05-10-12 | PWS   |
|           |        |      |                            |          |       |
|           |        |      |                            |          |       |

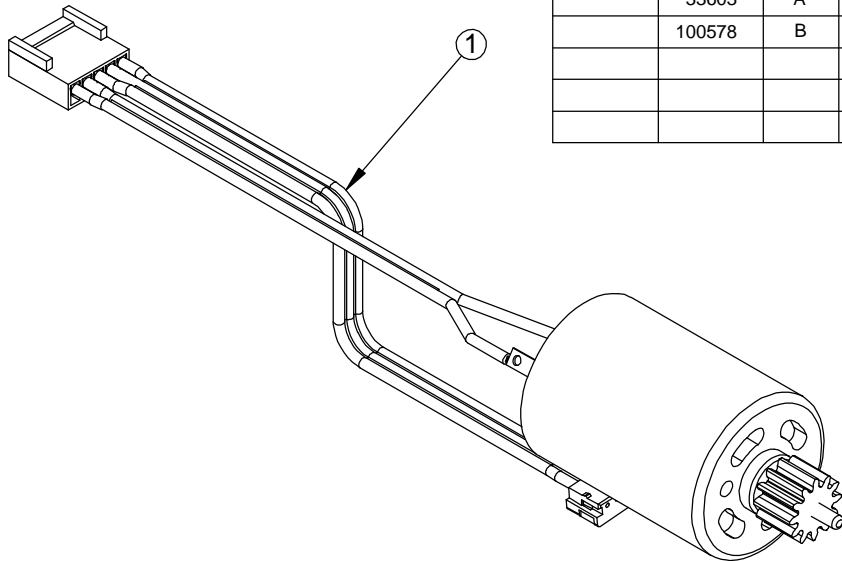

| ITEM NO. | PART NUMBER | DESCRIPTION               | QTY. |
|----------|-------------|---------------------------|------|
| 1        | BR43258     | HARNES, MOTOR/PHOTO, 5800 | 1    |
| 2        | BR16895     | BAG                       | 1    |
| 3        | BR43002     | LABEL                     | 1    |

THIS DRAWING MUST BE COMPARED TO THE ERP SYSTEM TO ENSURE CORRECT REVISION LEVEL PRIOR TO USE.

THE COMPONENT, PART, OR ASSEMBLY DESCRIBED IN THIS DOCUMENT MUST COMPLY WITH THE EU (EUROPEAN UNION) DIRECTIVE: RoHS DIRECTIVE 2002/95/EC.

LAST SAVED IN SMARTTEAM  
5/15/2012 3:51:46 PM

CRITICALITY SYMBOLS PER QPSP-001.2

- LEVEL I
- LEVEL II
- LEVEL III

THIS DOCUMENT IS SOLELY THE PROPERTY OF PENTAIR WATER TREATMENT. REPRODUCTION, USE DISCLOSURE, OR TRANSMISSION OF THIS DOCUMENT OR DETAILS CONTAINED HEREIN, IN PART OR IN WHOLE, IS PROHIBITED WITHOUT THE WRITTEN CONSENT OF PENTAIR WATER TREATMENT ENGINEERING. THIS DOCUMENT AND ANY COPIES SHALL BE RETURNED TO PENTAIR WATER TREATMENT UPON WRITTEN REQUEST.

DO NOT SCALE DRAWING. DIMS. ARE IN INCHES [mm]  
INTERPRET DIMS AND TOLERANCES PER ASME Y14.5M -1994 UNLESS OTHERWISE SPECIFIED:  
CORNER FILLETS R.005-.020 [.127-.508]  
TOLERANCES:  
ANGLES : ± 1°  
1 PLACE .X: ± .015 [0.38]  
2 PLACE .XX: ± .01 [0.3]  
3 PLACE .XXX: ± .005 [0.13]

THIRD ANGLE PROJECTION

| APPROVALS    | DATE     |
|--------------|----------|
| DRAWN<br>ZAL | 09-07-11 |
| CHECKED      |          |
| APPROVED     |          |



Pentair Residential Filtration

TITLE MOTOR ASSY, 5800

SIZE A

DWG NO. BR61835

REV B

SCALE 1:1

SOLIDWORKS FORMAT

SHEET 1 OF 1

2

1