

INTERNAL USE ONLY

OBSOLETE  
SEE ECO F563

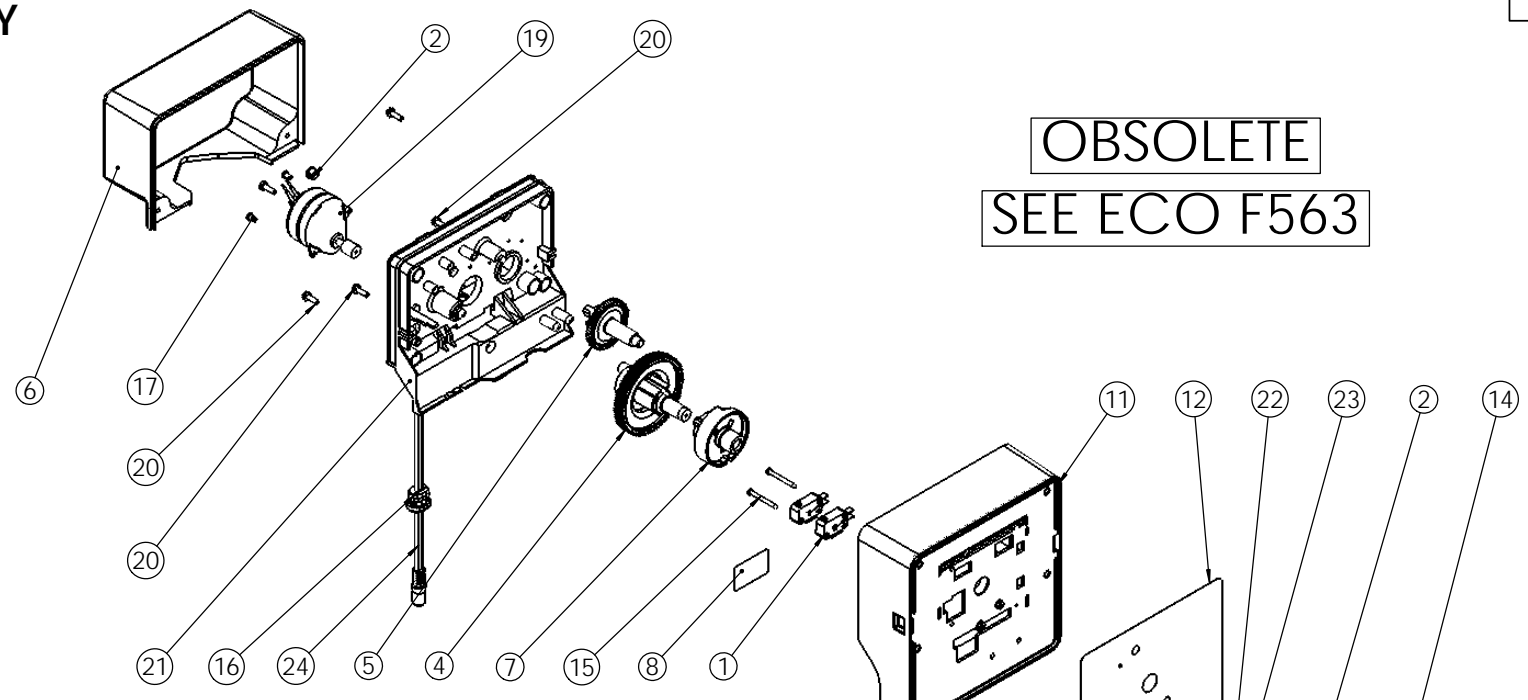

ITEM	PART NO	QTY	DESCRIPTION
1	10218	2	MICROSWITCH
2	13868	2	BUSHING
3	14968	1	METER FLEXIBLE ASSY
4	18211-01	1	GEAR, MAIN, DOWNFLOW, MACHD
5	BR18228	1	CAM, BRINE VALVE
6	18259-02	1	COVER, BACK, BLACK
7	BR19927	1	CAM, RAYNE, D/F, SE
8	21271	1	SERIAL NUMBER LABEL
9	21759	2	TIE RAP
10	25651	1	24v, STANDARD TRANSFORMER
11	28047	1	FRONT PLATE BLACK 5000 MECHANICAL
12	28049	1	FRONT LABEL FOR MECHANICAL 5000
13	28070	1	WIRE HARNESS FOR 5165
14	28335	1	TIMER 3210 ASSY FOR 5100 DF
15	BU11413	2	SCREW 2.9x32
16	BR13547	1	STRAIN RELIEF, FLAT CORD
17	BR13602	2	SCREW, PHIL RD HD, 6-32 X 5/16
18	BR40422	2	WIRE NUT
19	40251	1	MOTOR, 24V - 50/60HZ
20	BU13296	5	SCREW #6-20 * 0.50 long
21	BU28703	1	Plate, Back, Auxiliary Microswitch
22	BU28301	1	CYCLE LABEL FOR 5100 DF
23	BU28303	1	INDEX LABEL FOR 5100
24	BU28552	1	TRANSFORMER WIRE HARNESS

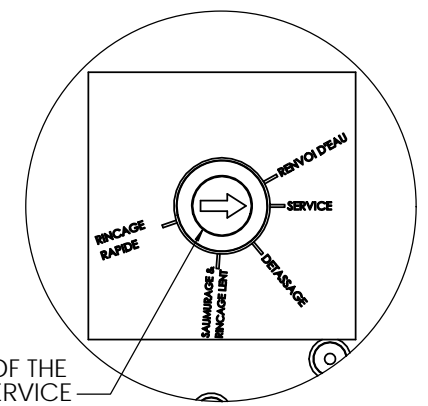
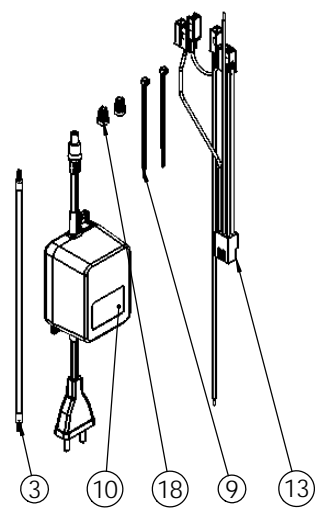

POSITION OF THE LABEL IN SERVICE



POWER HEAD 5100 DF ECO

BU28096