

REVISIONS				
ECN	Rev.	Description	Date (dd/mm/yy)	Approved
	A	Created on Solidworks	2/03/10	CHT

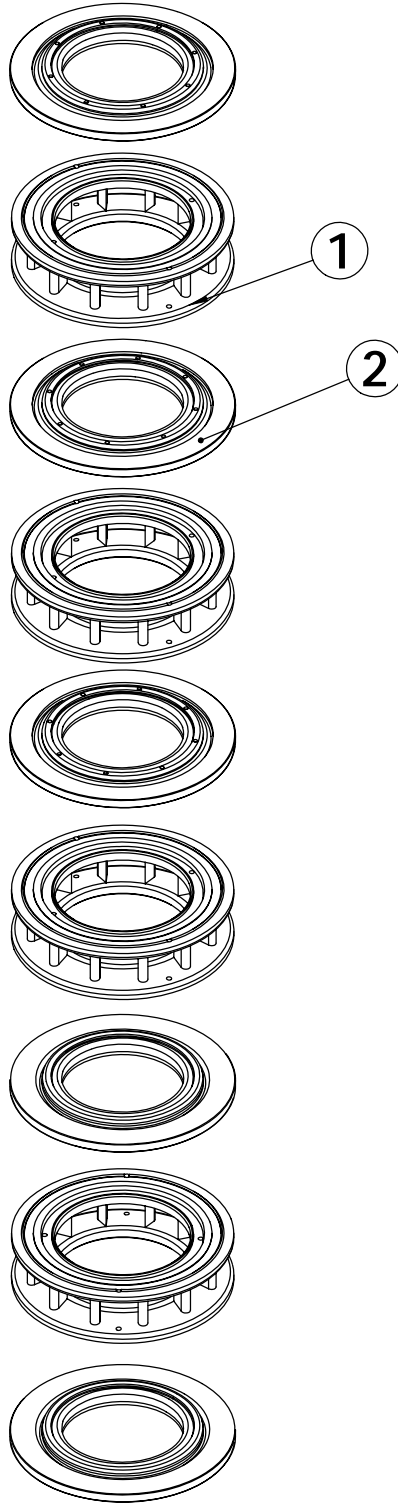

INTERNAL USE ONLY

ITEM	PN	DESCRIPTION	QTY
1	14241-02	SPACER	4
2	BU28715	SEAL, DOMESTIC & TWIN	5



SEAL AND SPACER KIT 4600/5600

BU28753

Chapitre 21