

REVISIONS				
ECN	Rev.	Description	Date (dd/mm/yy)	Approved
	A	CREATED ON SOLIDWORKS	21/05/08	LD

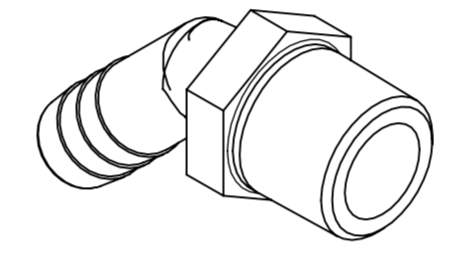
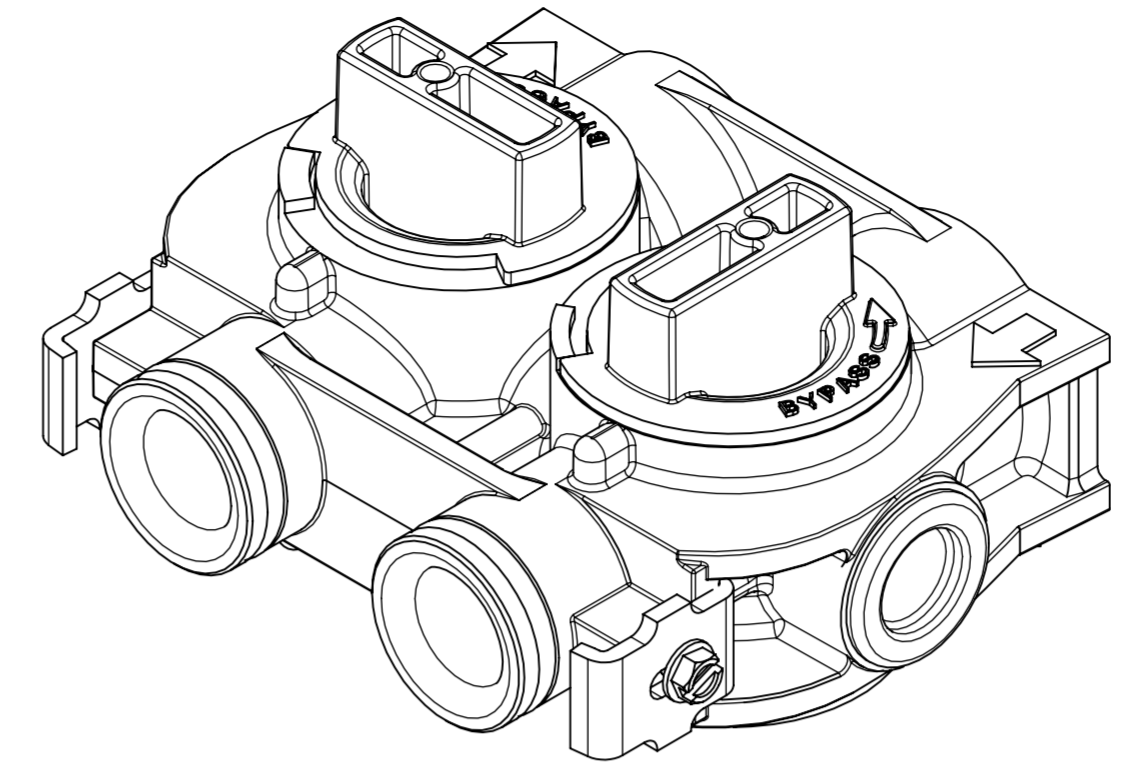
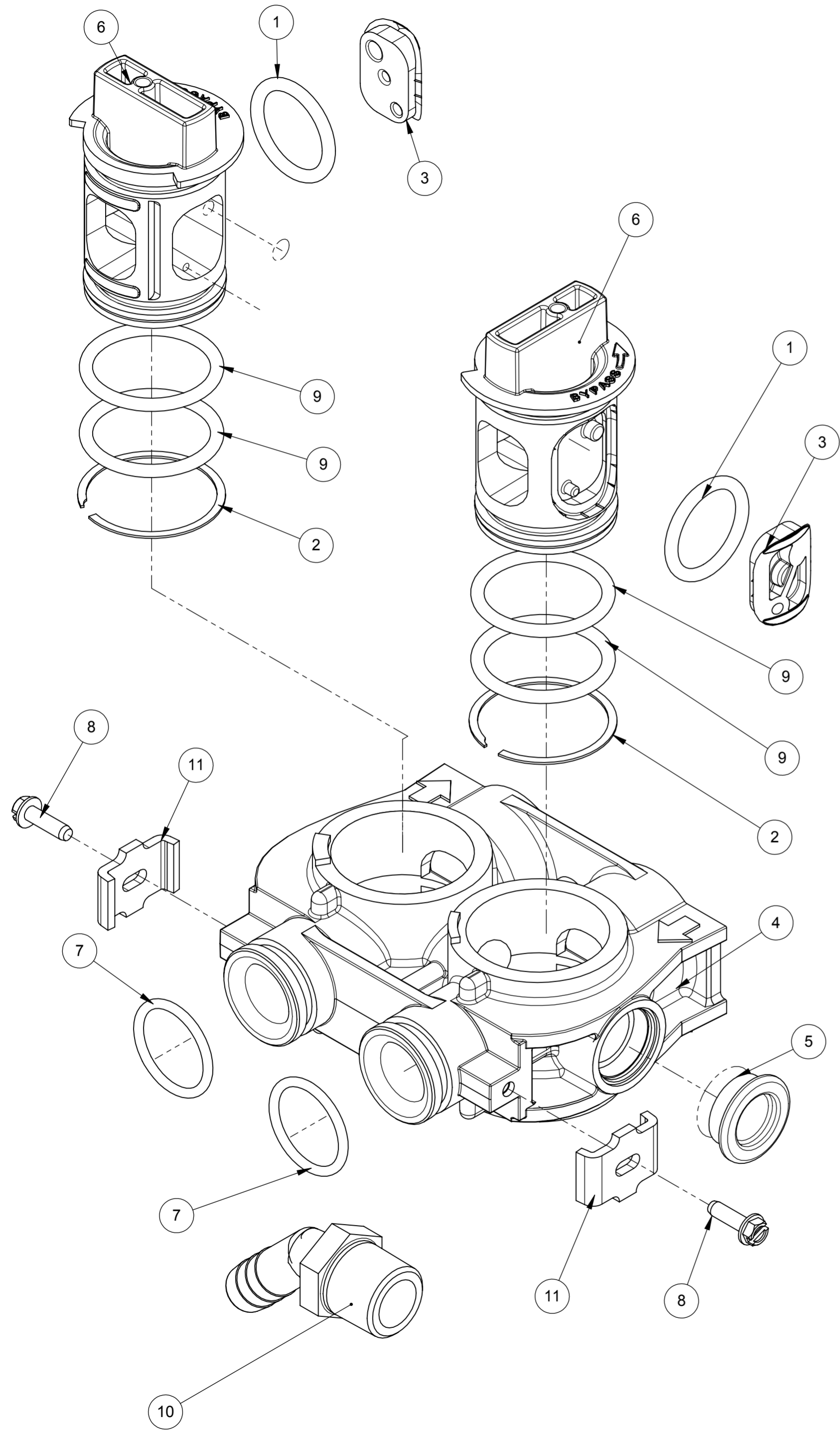

TEST PROCEDURE TEST FIXTURE #FD1186

1. ASSEMBLE BYPASS ASSEMBLY
2. BY-PASS PLUG ITEM 6 CAN BE ASSEMBLED TO BYPASS BODY IN ANY DIRECTION, BUT ENSURE ALL BY-PASS PLUGS ARE IN THE "OFF" (CLOSED) POSITION BEFORE TESTING.
3. LOAD 5 BYPASS ASSEMBLIES ON TEST FIXTURE WITH PLUG LEVERS DOWNWARD (MALE PORTS WITH O-RINGS FIT INTO FIXTURE RECEPTACLES)
4. ACTIVATE FIXTURE
-PARTS ARE AUTOMATICALLY CLAMPED INTO FIXTURE AND SUBMERGED IN WATER
-40 PSI AIR PRESSURE IS APPLIED TO BOTH MALE PORTS ON BYPASS ASSEMBLY
-ALL 6 O-RINGS WILL BE TESTED IN THIS CONFIGURATION.
5. OBSERVE SUBMERGED PARTS FOR 20 SECONDS. A TIMER WILL TURN ON A LIGHT WHEN THE 20 SECONDS IS COMPLETED. THE OPERATOR WILL NEED TO RELEASE PRESSURE WITH YELLOW BUTTON.
6. CONSISTENT OR STREAMING AIR BUBBLES INDICATES FAILURE

PACKAGING INSTRUCTIONS

1. FOLD AND TAPE CARTON BOTTOM #40130.
 2. INSERT 2 OF DIVIDER #40126 & 3 OF DIVIDER #40127 INTO CARTON. THIS WILL PROVIDE 12 SEPARATE COMPARTMENTS TO HOLD 12 BYPASS ASSEMBLIES.
 3. ENCLOSE EACH BYPASS ASSEMBLY IN THE "OFF" CLOSED POSITION IN A 8"X10" POLY BAG.
 4. PLACE A BR19699 WITH EACH BYPASS
 5. COVER WITH #40128 PAD.
 6. LAY WARRANTY SHEET ON TOP OF PAD, CLOSE AND TAPE BOX.
 7. PLACE LABEL ON SIDE OF CARTON SO THAT LABEL CAN BE READ WHEN BOXES ARE STACKED.
- REFERENCE PENTAIR PROCEDURES #OP-06 & #PURWI-01 FOR LABEL CONTENT & DISPLAY.

PACKAGING MATERIALS

CARTON	#40130	QTY: 1
3 SLOT DIVIDER	#40126	QTY: 2
2 SLOT DIVIDER	#40127	QTY: 3
PAD	#40128	QTY: 1
WARRANTY SHEET	#40957	QTY: 1
POLY BAG, 8" X 10"		QTY: 12
CARTON LABEL, 4" X 6"		QTY: 1

ITEM NO.	QTY.	PART NO.	DESCRIPTION
1	2	18660	O-RING, -213
2	2	18662	RING,RETAINING , BY-PASS
3	2	41106	SEAL, RETAINER, BY-PASS, 3/4"
4	1	41107	BODY, BY-PASS, 3/4"
5	1	41108	PLUG, BODY, BY-PASS, 3/4"
6	2	41109	PLUG, BYPASS 3/4" PLASTIC
7	2	BR13305	O-RING, -199
8	2	BR13314	SCREW, HX WASHER HEAD, 8-18 X .60
9	4	BR18661	O-RING, -218
10	1	BR19699	HOSE BARB, 45 DEG -1/2 NPT
11	2	BU13255	CLIP, MOUNTING

ROHS NOTES :
THE COMPONENT, PART, OR ASSEMBLY DESCRIBED IN THIS DOCUMENT MUST COMPLY WITH THE FOLLOWING EU (EUROPEAN UNION) DIRECTIVES:
ROHS DIRECTIVE 2002/95/EC, WEE DIRECTIVE 2002/96/EC, AND ELV DIRECTIVE 2000/53/EC.
THESE DIRECTIVES RESTRICT THE USE OF LEAD, CADMIUM, MERCURY, CHROMIUM, PBB, PBDE, AND OTHER HAZARDOUS MATERIALS.
SEE THE TERMS AND CONDITIONS OF THE CONTRACT (PURCHASE ORDER) FOR MORE INFORMATION.

<p>All drawings and specifications as well as processes, materials, compounds and other similar criteria are to be strictly adhered to. No modifications allowed without prior written approval.</p> <p>TOLERANCES (UNLESS OTHERWISE SPECIFIED)</p> <table border="0"> <tr> <td>32</td> <td>+1 mm</td> </tr> <tr> <td>25.0</td> <td>+0.5 mm</td> </tr> <tr> <td>25.00</td> <td>+0.10 mm</td> </tr> <tr> <td>ANGULAR</td> <td>+1°</td> </tr> </table> <p>Break all exposed sharp corners 0.25 x 45° max.</p> <p>DO NOT SCALE DRAWING DIMENSIONS - MM (INCH)</p>	32	+1 mm	25.0	+0.5 mm	25.00	+0.10 mm	ANGULAR	+1°	<p>THIRD ANGLE PROJECTION</p> <p>Material: NA</p> <p>Drawn: CHT Date: 21/05/08</p> <p>Approved: LD Date: 21/05/08</p>	<p>Denotes Critical Dimension</p> <p>Denotes Revision</p> <p>Pentair Water</p> <p>Pentair Water France 14,0, Av Rolland Garros 78532 Buc cedex France</p> <p>Title: BYPASS ASSEMBLY, 3/4" PLASTIC</p> <p>Scale: 1:1 Filename: BU60049 Weight (kg): X Sheet: 1 of 1</p> <p>Port #: BU60049 Dwg #: BU60049</p>
	32	+1 mm								
25.0	+0.5 mm									
25.00	+0.10 mm									
ANGULAR	+1°									

This drawing is the absolute property of Pentair Water France. It may not be reproduced in any form without the written permission of Pentair Water France.

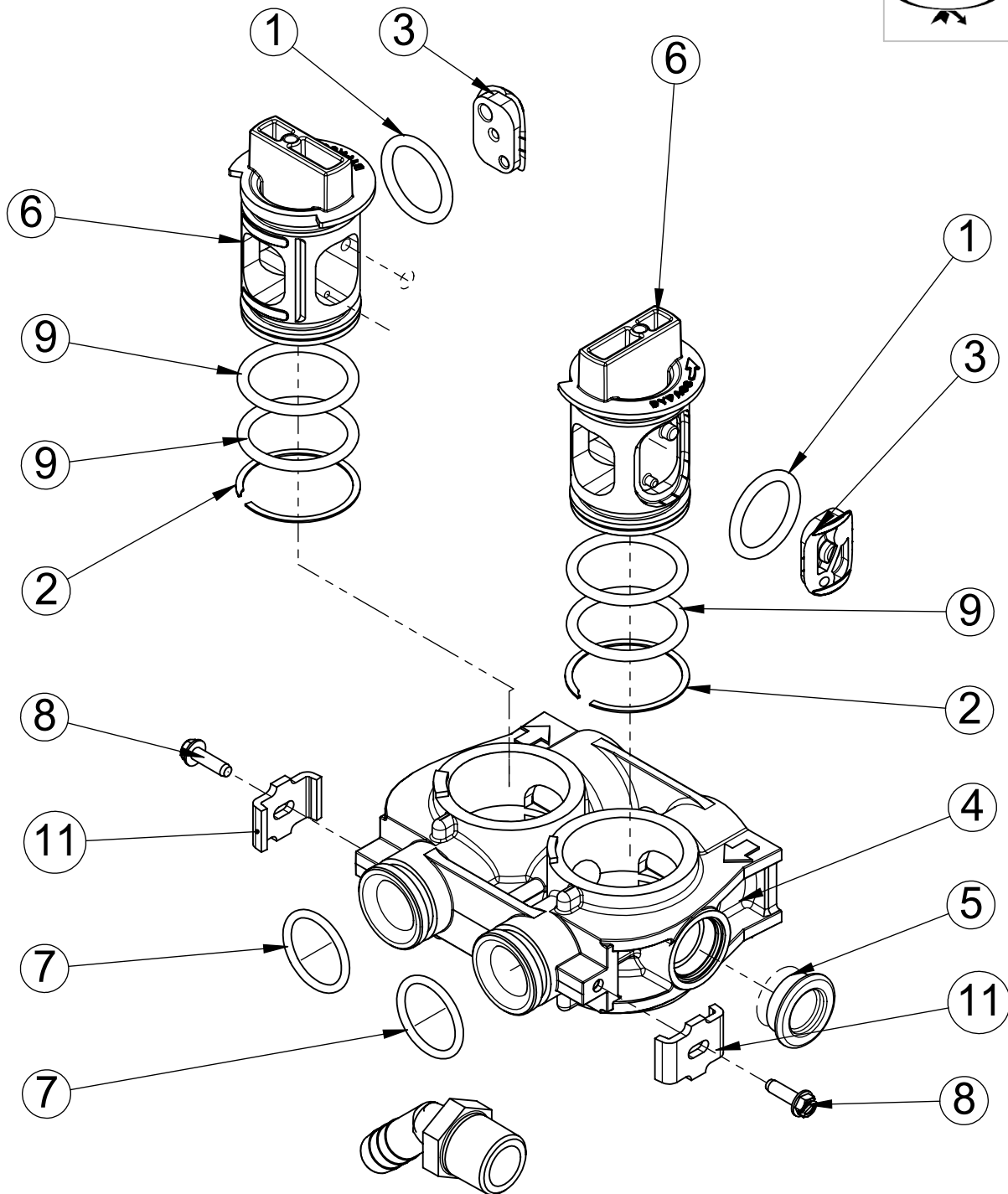

ITEM	QTY	PART NO.	DESCRIPTION	NOM
1	2	18660	O-RING, -213	JOINT TORIQUE
2	2	18662	RING,RETAINING , BY-PASS	BAGUE DE MAINTIEN
3	2	41106	SEAL, RETAINER, BY-PASS, 3/4"	PLAQUE DE RETENUE JOINT
4	1	41107	BODY, BY-PASS, 3/4"	CORPS BY-PASS 3/4"
5	1	41108	PLUG, BODY, BY-PASS, 3/4"	BOUCHON
6	2	41109	PLUG, BYPASS 3/4" PLASTIC	PLUG BY PASS 3/4" PLASTIC
7	2	BR13305	O-RING, -199	
8	2	BR13314	SCREW, HX WASHER HEAD, 8-18 X .60	VIS
9	4	BR18661	O-RING, -218	JOINT
10	1	BR19699	HOSE BARB, 45 DEG -1/2 NPT	COUDE 45° - 1/2 NPT
11	2	BU13255	CLIP, MOUNTING	CLIP