

REVISIONS				
ECN	Rev.	Description	Date (dd/mm/yy)	Approved
	D	BU28600 was BU28528	21/09/09	LD
	E	BU11413 was BR14923	23/10/09	LD
	F	BR18202 was 18202	27/10/09	MAN
	G	Removed SE option	05/01/10	CHT
	H	Rename 5000 SXT ECO DF and 5000 SXT TC DF as PH5000-001 and PH5000-002	24/03/10	CHT
F5152	J	Rename 5000 SXT TC Filter DF as PH5000-003	25/03/10	CHT

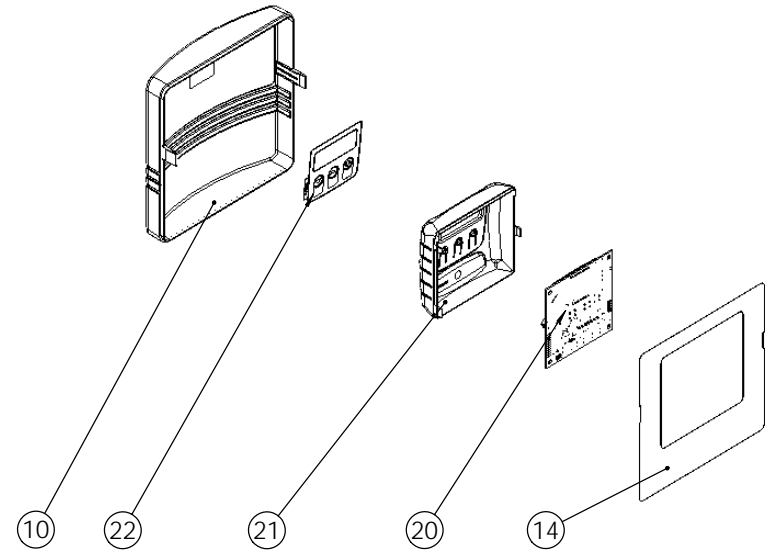

AUXILIARY MICROSWITCH OPTION					
ITEM	PN	DESCRIPTION	NO MICRO SWITCH	NOT WIRED QTY	WIRED QTY
1	BR18202	BACK PLATE 5000 SE	1	1	-
	BU28703	PLATE, BACK, AUXILIARY MICROSWITCH	-	-	1
16	BU13296	SCREW #6-20 x 0.50 long	-	-	+2
23	10218	MICROSWITCH	-	1	1
24	BR11805	SCREW	-	2	2
25	19282	BRACKET TERMINAL BLOCK	-	-	1
26	23653-05	TERMINAL BLOCK 5 POSITIONS	-	-	1
27	24934	TERMINAL STRIP LABEL	-	-	1
28	26044	WIRE HARNESS , AUX. SWITC, 5000	-	-	1

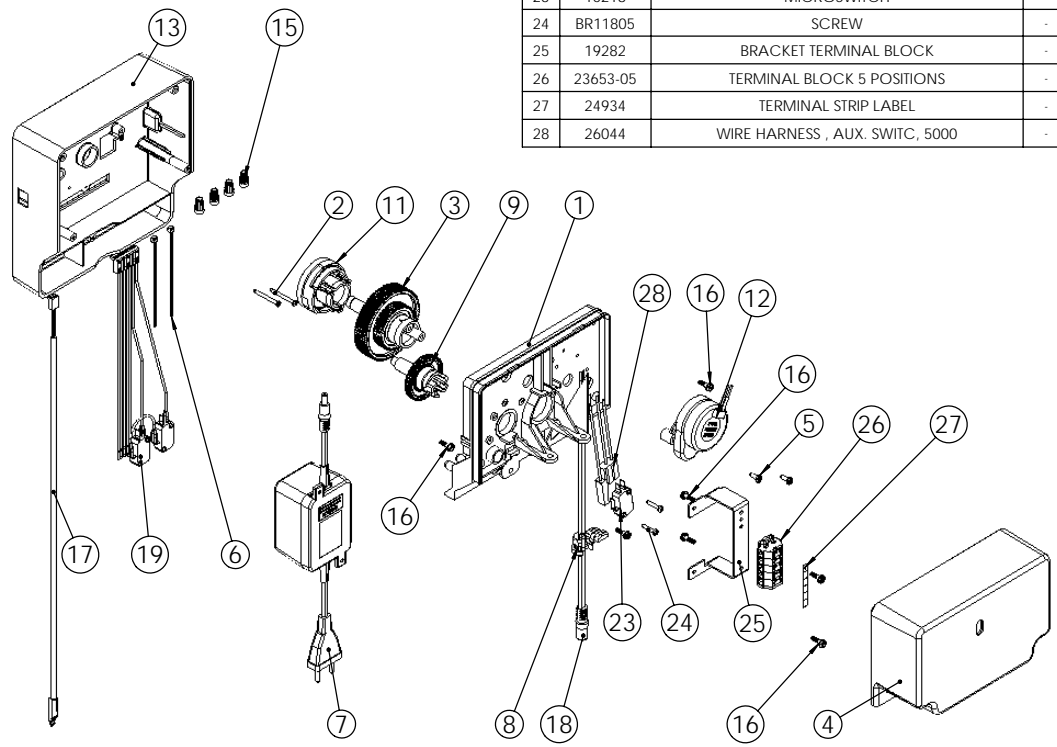

ITEM	PN	DESCRIPTION	PH5000-001 Eco SXT DF QTY	PH5000-002 TC SXT DF QTY	PH5000-003 TC SXT Filter QTY	Eco SXT Filter QTY	TC SXT UF QTY	Eco SXT UF QTY
1	BR18202	BACK PLATE 5000 SE BLACK	1	1	1	1	1	1
2	BU11413	SCREW 2.9x32	2	2	2	2	2	2
3	18211-01	GEAR MAIN DF MACHINED	1	1	-	-	-	-
3	18251-01	GEAR MAIN UF MACHINED	-	-	1	1	1	1
4	18259-02	COVER, BACK, BLACK	1	1	1	1	1	1
5	19160	SCREW, #6-32 X 3/8 PAN HEAD	2	2	2	2	2	2
6	21759	TIE RAP	2	2	2	2	2	2
7	25651	24v, STANDARD TRANSFORMER	1	1	1	1	1	1
8	BR13547	STRAIN RELIEF, ROUND CORD	1	1	1	1	1	1
9	BR18228	CAM, BRINE VALVE	1	1	-	-	-	-
9	BR18252	CAM, BRINE VALVE UPFLOW	-	-	1	1	1	1
10	BR18260-00	COVER, FRONT, 5000SE	1	1	1	1	1	1
11	BR19927	CAM, RAYNE, D/F, SE	1	1	-	-	-	-
11	BR19928	Cam, Switch, Up Flow	-	-	1	1	1	1
12	BR40251	MOTOR, 24V - 50/60HZ	1	1	1	1	1	1
13	BR40269-02	PLATE, FRONT	1	1	1	1	1	1
14	BR40326	LABEL, COVER-UP, PROFLOSE	1	1	1	1	1	1
15	BR40422	WIRE NUT	4	4	4	4	4	4
16	BU13296	SCREW #6-20 * 0.50 long	5	6	5	5	5	5
17	BU19791-01	ASSY TURBINE METER CABLE	1	-	-	1	-	1
18	BU28552	TRANSFORMER WIRE HARNESS	1	1	1	1	1	1
19	BU28600	HARNESS POWER & HOME/STEP SE	1	1	1	1	1	1
20	BR42766-02	CIRCUIT BOARD, SXT, PROGRAMMED	1	1	1	1	1	1
21	BR42635	FRONT COVER, SXT, SQUARE	1	1	1	1	1	1
22	BR42637	LABEL, DISPLAY, SXT	1	1	1	1	1	1



POWER HEAD 5000 SXT

PH5000-XX
Chapitre 06