

REVISIONS				
ECN	Rev.	Description	Date (dd/mm/yy)	Approved
	a	Created on Solidworks	26/04/12	CHT

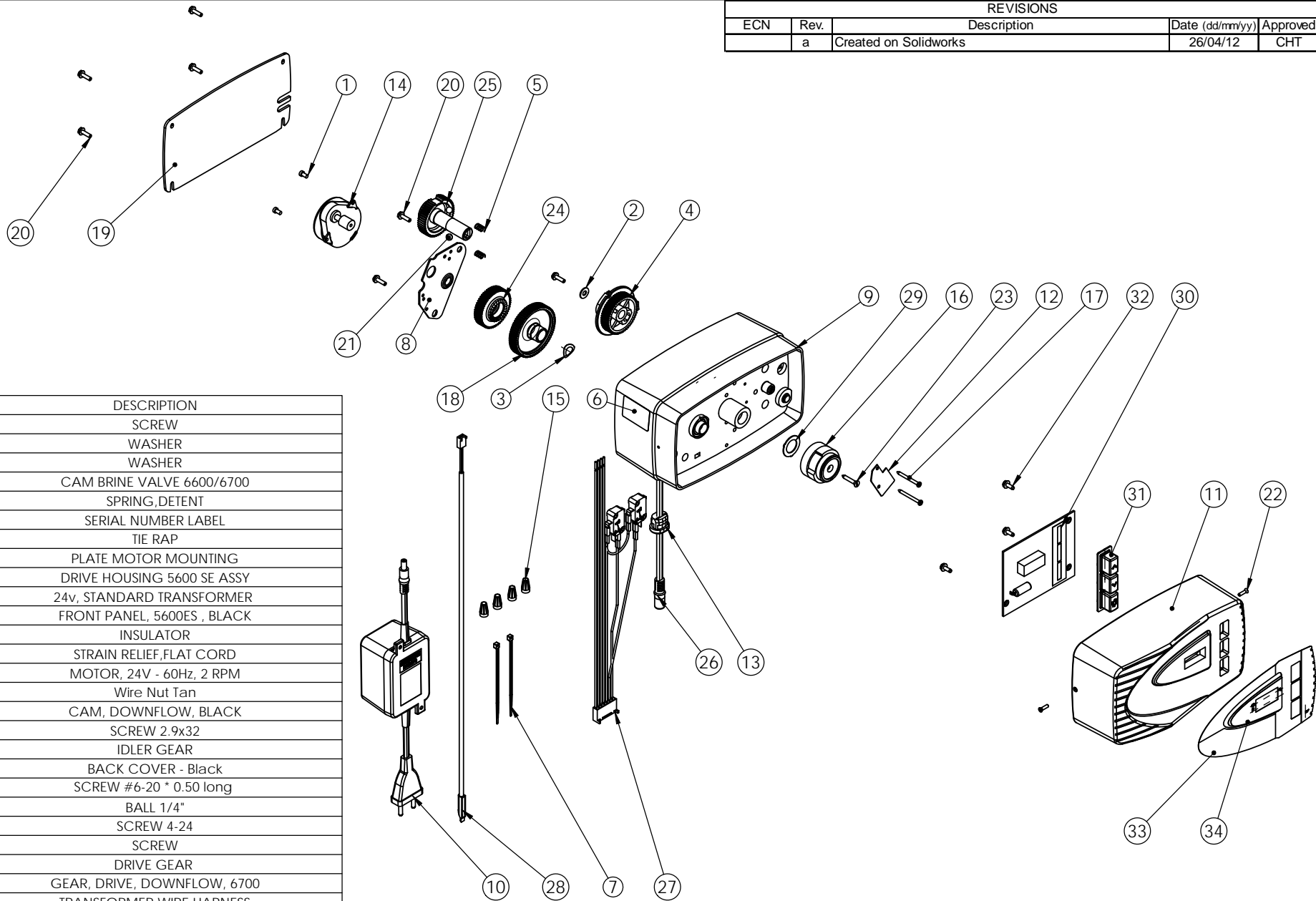

ITEM	PN	QTY	DESCRIPTION
1	11384	2	SCREW
2	12037	1	WASHER
3	13299	1	WASHER
4	18722	1	CAM BRINE VALVE 6600/6700
5	BR14457	2	SPRING, DETENT
6	21271	1	SERIAL NUMBER LABEL
7	21759	2	TIE RAP
8	23341	1	PLATE MOTOR MOUNTING
9	28381-02	1	DRIVE HOUSING 5600 SE ASSY
10	25651	1	24v, STANDARD TRANSFORMER
11	28463-10	1	FRONT PANEL, 5600ES , BLACK
12	BR14087	1	INSULATOR
13	BR13547	1	STRAIN RELIEF, FLAT CORD
14	16944	1	MOTOR, 24V - 60Hz, 2 RPM
15	BU28777	4	Wire Nut Tan
16	BR17438	1	CAM, DOWNFLOW, BLACK
17	BU11413	2	SCREW 2.9x32
18	BU13017	1	IDLER GEAR
19	BU13229-02	1	BACK COVER - Black
20	BU13296	7	SCREW #6-20 * 0.50 long
21	BU13300	2	BALL 1/4"
22	BU13898	2	SCREW 4-24
23	BU15151	1	SCREW
24	BU23045	1	DRIVE GEAR
25	BR42933	1	GEAR, DRIVE, DOWNFLOW, 6700
26	BU28552	1	TRANSFORMER WIRE HARNESS
27	28060	1	HARNESS POWER ND CASTAGNETTI
28	BU19791-01	1	ASSY TURBINE METER CABLE
29	BR19079	1	WASHER, FRICTION
30	28036	1	CIRCUIT BOARD FOR NEW DESIGN
31	28035	1	PAD BUTTON VERTICAL
32	BU17020	3	SCREW, HEX WASHER HEAD, #6-20 X .38
33	BU28662	1	5600ES, DF, FRONT LABEL ( MAIN )
34	BU28663	1	LUBRON , 5600ES, SSmall FRONT LABEL



POWER HEAD ASSY 5600 SXT DOWN FLOW

PH56SE-500